



**KLX250**

**Motorcycle  
Motocyclette  
Motorrad**

**OWNER'S MANUAL  
MANUEL DE L'UTILISATEUR  
BETRIEBSANLEITUNG**



ENGLISH

# Motorcycle **Owner's Manual**



Whenever you see the symbols shown below, heed their instructions! Always follow safe operating and maintenance practices.

 **DANGER**

**DANGER** indicates a hazardous situation which, if not avoided, will result in death or serious injury.

 **WARNING**

**WARNING** indicates a hazardous situation which, if not avoided, could result in death or serious injury.

 **CAUTION**

**CAUTION** indicates a hazardous situation which, if not avoided, could result in minor or moderate injury.

**NOTICE**

**NOTICE** is used to address practices not related to personal injury.

**NOTE**

- *This note symbol indicates points of particular interest for more efficient and convenient operation.*

## FOREWORD

Congratulations on your purchase of a new Kawasaki motorcycle. Your new motorcycle is the product of Kawasaki's advanced engineering, exhaustive testing, and continuous striving for superior reliability, safety and performance.

**Please read this Owner's Manual carefully before riding** so that you will be thoroughly familiar with the proper operation of your motorcycle's controls, its features, capabilities, and limitations. This manual offers many safe riding tips, but its purpose is not to provide instruction in all the techniques and skills required to ride a motorcycle safely. Kawasaki strongly recommends that all operators of this vehicle enroll in a motorcycle rider training program to attain awareness of the mental and physical requirements necessary for safe motorcycle operation.

To ensure a long, trouble-free life for your motorcycle, give it the proper care and maintenance described in this manual. For those who would like more detailed information on their Kawasaki Motorcycle, a Service Manual is available for purchase from any authorized Kawasaki motorcycle dealer. The Service Manual contains detailed disassembly and maintenance information. Those who plan to do their own work should, of course, be competent mechanics and possess the special tools described in the Service Manual.

Keep this Owner's Manual aboard your motorcycle at all times so that you can refer to it whenever you need information.

This manual should be considered a permanent part of the motorcycle and should remain with the motorcycle when it is sold.

All rights reserved. No part of this publication may be reproduced without our prior written permission.

This publication includes the latest information available at the time of printing. However, there may be minor differences between the actual product and illustrations and text in this manual.

All products are subject to change without prior notice or obligation.

**KAWASAKI HEAVY INDUSTRIES, LTD.**  
**Motorcycle & Engine Company**

---

## TABLE OF CONTENTS

---

<b>SPECIFICATIONS</b> .....	8	Left Handlebar Switches .....	32
<b>LOCATION OF PARTS</b> .....	12	Dimmer Switch: .....	32
<b>LOCATION OF LABELS</b> .....	15	Turn Signal Switch:.....	33
<b>LOADING INFORMATION</b> .....	18	Horn Button: .....	33
<b>GENERAL INFORMATION</b> .....	21	Fuel Tank Cap .....	33
Meter Instruments .....	21	Fuel .....	34
Meter Instruments:.....	22	Fuel Requirements: .....	34
Tachometer Gauge: .....	22	Filling the Tank:.....	36
Speedometer : .....	22	Stand.....	38
Odometer/Trip Meter AB/Fuel		Helmet Hook .....	39
Warning Message (ODO/TRIP		Tool Kit Bag/Tool Kit .....	40
AB): .....	23	Seat.....	40
Indicator/Warning Light:.....	27	<b>BREAK-IN</b> .....	42
Warning/Indicator Lights: .....	27	<b>HOW TO RIDE THE MOTORCYCLE</b> .	44
Key .....	29	Starting the Engine .....	44
Ignition Switch/Steering Lock.....	29	Jump Starting .....	46
Right Handlebar Switches.....	31	Moving Off.....	49
Engine Stop Switch: .....	31	Shifting Gears .....	50
Starter Button: .....	31	Braking.....	51
Headlight Switch: .....	31	Stopping the Engine.....	52



Stopping the Motorcycle in an Emergency .....	53	Throttle Grip .....	96
Parking .....	54	Idle Speed .....	98
Catalytic Converter.....	56	Clutch.....	99
<b>SAFE OPERATION</b> .....	58	Drive Chain .....	102
Safe Riding Technique .....	58	Brakes .....	109
Daily Safety Checks.....	61	Brake Light Switches.....	113
Additional Considerations for Off Road Operation .....	64	Front Fork.....	115
<b>MAINTENANCE AND ADJUSTMENT</b>	65	Rear Shock Absorber.....	117
Periodic Maintenance Chart.....	66	Wheels .....	120
Engine Oil .....	77	Battery .....	124
Cooling System.....	83	Headlight Beam.....	129
Spark Plugs.....	87	Fuses .....	131
Valve Clearance .....	89	Cleaning Your Motorcycle .....	132
Kawasaki Clean Air System.....	89	<b>STORAGE</b> .....	136
Air Cleaner .....	90	<b>ENVIRONMENTAL PROTECTION</b> .....	139
		<b>LABEL INFORMATION</b> .....	140

## 8 SPECIFICATIONS

---

## SPECIFICATIONS

---

### PERFORMANCE

Maximum Horsepower	16 kW (22 PS) @7 500 r/min (rpm)
Maximum Torque	20.5 N·m (2.09 kg·m, 15.1 ft·lb) @7 000 r/min (rpm)
Minimum Turning Radius	2.4 m (94.5 in.)

### DIMENSIONS

Overall Length	2 200 mm (86.62 in.)
Overall Width	820 mm (32.28 in.)
Overall Height	1 205 mm (47.4 in.)
Wheelbase	1 430 mm (56.30 in.)
Road Clearance	285 mm (11.22 in.)
Curb Mass	138 kg (304 lb)

### ENGINE

Type	DOHC, single-cylinder, 4-stroke, liquid-cooled
Displacement	249 cm <sup>3</sup> (15.2 cu in.)
Bore x Stroke	72.0 x 61.2 mm (2.83 x 2.41 in.)

Compression Ratio	11.0 : 1
Starting System	Electric starter
Fuel System	FI (Fuel Injection)
Ignition System	CDI
Ignition Timing (Electronically advanced)	10° BTDC @1 300 r/min (rpm) ~ 34° BTDC @11 000 r/min (rpm)
Spark Plugs	NGK CR8E
Lubrication System	Forced lubrication (wet sump)
Engine Oil	
Type:	API SG, SH, SJ, SL or SM with JASO MA, MA1 or MA2
Viscosity:	SAE 10W-40
Capacity:	1.3 L (1.4 US qt)
Coolant Capacity	1.3 L (1.4 US qt)

## **TRANSMISSION**

Transmission Type	6-speed, return shift
Clutch Type	Wet, multi disc
Driving System	Chain drive

## 10 SPECIFICATIONS

Primary Reduction Ratio	2.800 (84/30)
Final Reduction Ratio	3.000 (42/14)
Overall Drive Ratio	8.000 (Top gear)
Gear Ratio	
1st	3.000 (30/10)
2nd	2.000 (30/15)
3rd	1.500 (27/18)
4th	1.250 (25/20)
5th	1.050 (21/20)
6th	0.952 (20/21)

### FRAME

Castor	26.5°
Trail	105 mm (3.31 in.)
Tire Size:	
Front	3.00-21 51P
Rear	4.60-18 63P

## Rim Size:

Front 21 × 1.60

Rear 18 × 2.15

Fuel Tank Capacity 7.7 L (2.04 US gal)

**ELECTRICAL EQUIPMENT**

Battery 12 V 6 Ah

Headlight 12 V 60/55 W

Tail/Brake Light 12 V 5/21 W

Specifications subject to change without notice, and may not apply to every country.

## LOCATION OF PARTS

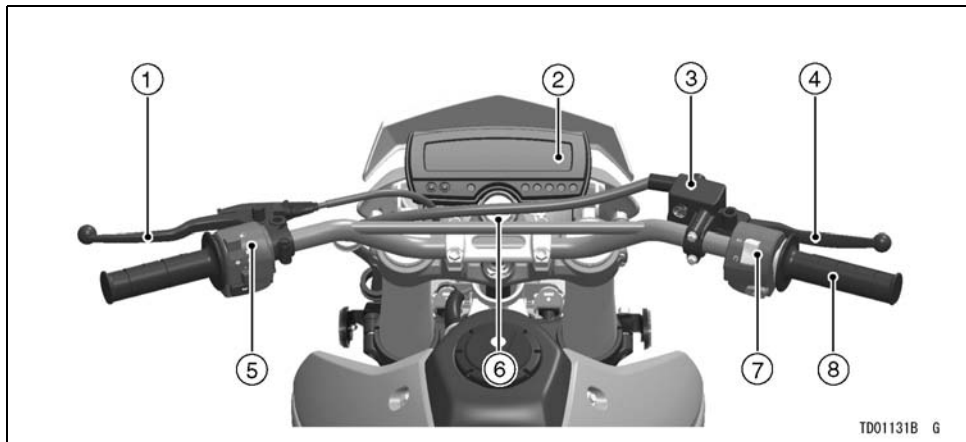

TD01131B G

- 1. Clutch Lever
- 2. Meter Instruments
- 3. Brake Fluid Reservoir (Front)
- 4. Front Brake Lever

- 5. Left Handlebar Switches
- 6. Ignition Switch/Steering Lock
- 7. Right Handlebar Switches
- 8. Throttle Grip

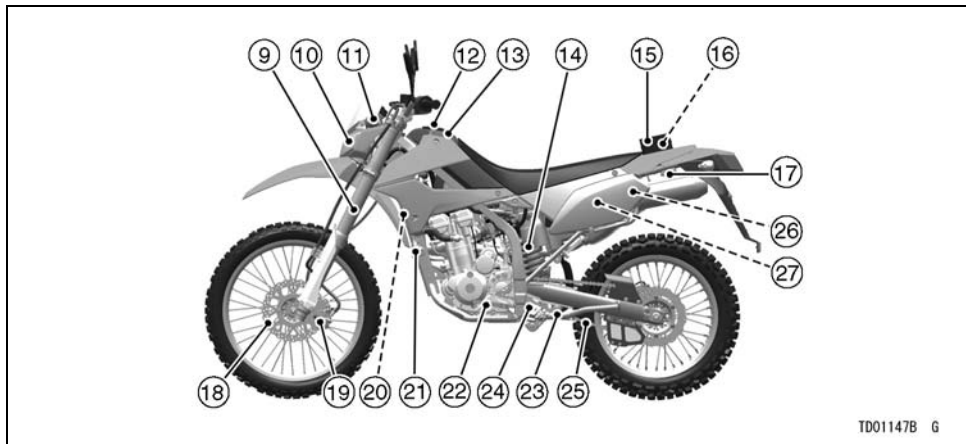

TD01147B G

- 9. Front Fork
- 10. Headlight
- 11. Turn Signal Light
- 12. Fuel Tank Cap
- 13. Fuel Tank
- 14. Rear Shock Absorber
- 15. Tool Kit Bag

- 16. Tool Kit
- 17. Helmet Hook
- 18. Brake Disc
- 19. Brake Caliper
- 20. Radiator
- 21. Horn
- 22. Shift Pedal

- 23. Side Stand
- 24. Side Stand Switch
- 25. Drive Chain
- 26. Coolant Reserve Tank
- 27. Battery

## 14 LOCATION OF PARTS

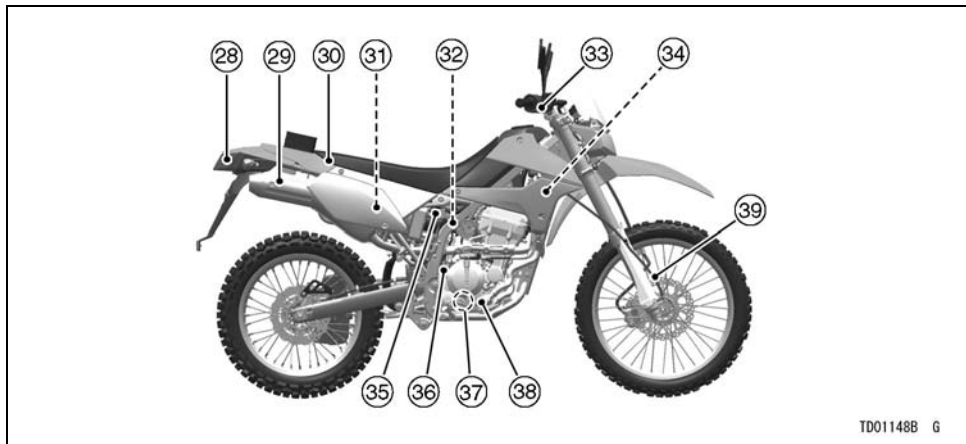

TD01148B 6

**28. Tail/Brake Light**

**29. Muffler**

**30. Seat**

**31. Air Cleaner Element**

**32. Idle Adjusting Screw**

**33. Front Brake Light**

**Switch**

**34. Radiator Cap**

**35. Brake Fluid Reservoir**

**(Rear)**

**36. Rear Brake Light**

**Switch**

**37. Oil Level Gauge**

**38. Rear Brake Pedal**

**39. Speedometer Lead**



---

## LOCATION OF LABELS

---

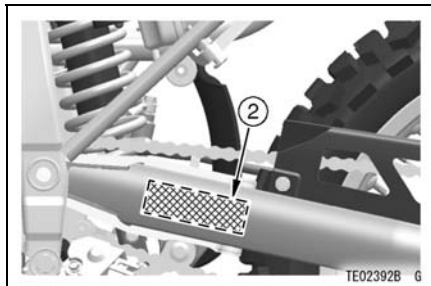
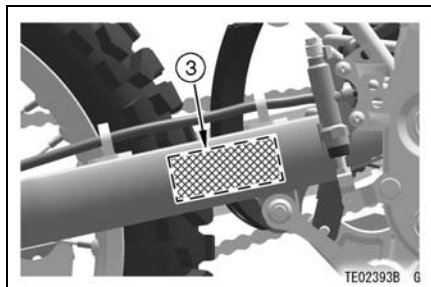
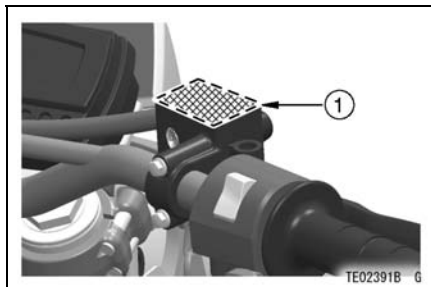

1. Brake Fluid (Front)
2. Important Drive Chain Information
3. Tire and Load Data

(For further information of label, refer to the "LABEL INFORMATION" chapter.)

## 16 LOCATION OF LABELS

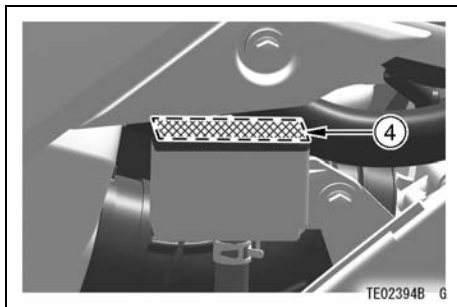

4. Brake Fluid (Rear)
5. Daily Safety Checks

(For further information of label, refer to the “LABEL INFORMATION” chapter.)

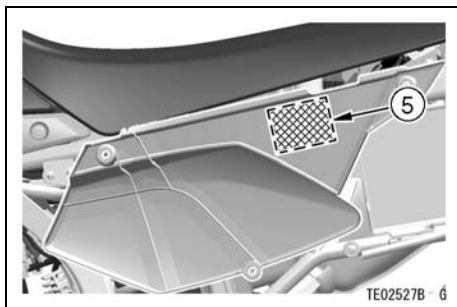

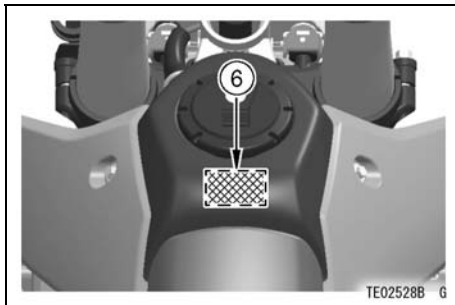

- 6. Unleaded Gasoline
- 7. Battery Poison/Danger

(For further information of label, refer to the “LABEL INFORMATION” chapter.)

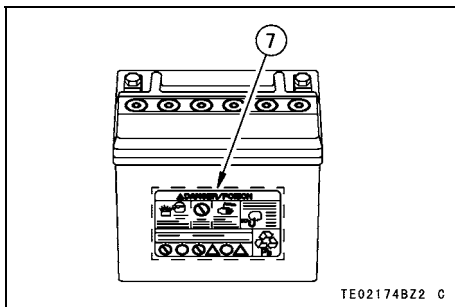

---

**LOADING INFORMATION**

---

** WARNING**

**Incorrect loading, improper installation or use of accessories, or modification of your motorcycle may result in an unsafe riding condition. Before you ride the motorcycle, make sure it is not overloaded and that you have followed these instructions.**

With the exception of genuine Kawasaki Parts and Accessories, Kawasaki has no control over the design or application of accessories. In some cases, improper installation or use of accessories, or motorcycle modification, will void the motorcycle warranty. In selecting and using accessories, and in loading the motorcycle,

you are personally responsible for your own safety and the safety of other persons involved.

**NOTE**

- *Kawasaki Parts and Accessories have been specially designed for use on Kawasaki motorcycles. We strongly recommend that all parts and accessories you add to your motorcycle be genuine Kawasaki components.*

Because a motorcycle is sensitive to changes in weight and aerodynamic forces, you must take extreme care in carrying cargo, passengers and/or in the fitting of additional accessories. The following general guidelines have

been prepared to assist you in making your determinations.

1. Any passenger should be thoroughly familiar with motorcycle operation. The passenger can affect control of the motorcycle by improper positioning during cornering and sudden movements. It is important that the passenger sit still while the motorcycle is in motion and not interfere with the operation of the motorcycle. Do not carry animals on your motorcycle.
2. You should instruct any passenger before riding to keep his feet on the passenger footpegs and hold on to the operator or seat strap. Do not carry a passenger unless he or she is tall enough to reach the footpegs and footpegs are provided.
3. All baggage should be carried as low as possible to reduce the effect on the motorcycle center of gravity. Baggage weight should also be distributed equally on both sides of the motorcycle. Avoid carrying baggage that extends beyond the rear of the motorcycle.
4. Baggage should be securely attached. Make sure that the baggage will not move around while you are riding. Recheck baggage security as often as possible (not while the motorcycle is in motion) and adjust as necessary.
5. Do not carry heavy or bulky items on a luggage rack. They are designed for light items, and overloading can affect handling due to changes in weight distribution and aerodynamic forces.
6. Do not install accessories or carry baggage that impairs the performance of the motorcycle. Make sure that you have not adversely

## 20 LOADING INFORMATION

affected any lighting components, road clearance, banking capability (i.e., lean angle), control operation, wheel travel, front fork movement, or any other aspect of the motorcycle's operation.

7. Weight attached to the handlebar or front fork will increase the mass of the steering assembly and can result in an unsafe riding condition.
8. Fairings, windshields, backrests, and other large items have the capability of adversely affecting stability and handling of the motorcycle, not only because of their weight, but also due to the aerodynamic forces acting on these surfaces while the motorcycle is in operation. Poorly designed or installed items can result in an unsafe riding condition.
9. This motorcycle was not intended to be equipped with a sidecar or to

be used to tow any trailer or other vehicle. Kawasaki does not manufacture sidecars or trailers for motorcycles and cannot predict the effects of such accessories on handling or stability, but can only warn that the effects can be adverse and that Kawasaki cannot assume responsibility for the results of such unintended use of the motorcycle. Furthermore, any adverse effects on motorcycle components caused by the use of such accessories will not be remedied under warranty.

### Maximum Load

Weight of rider, passenger, baggage, and accessories must not exceed 181 kg (399 lb).
---

# GENERAL INFORMATION

## Meter Instruments

- A. MODE Button
- B. RESET Button
- C. Tachometer Gauge
- D. Odometer/Trip Meter  
AB/Fuel Warning Message
- E. Speedometer
- F. Clock
- G. Coolant Temperature  
Warning Light
- H. High Beam Indicator Light
- I. Neutral Indicator Light
- J. Turn Signal Indicator Light
- K. Red Zone
- L. FI (Fuel Injection)  
Warning Light
- M. Fuel Level Indicator Light

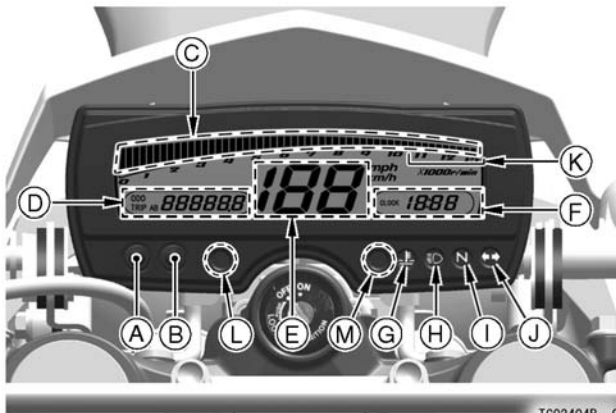

## 22 GENERAL INFORMATION

### Meter Instruments:

The meter displays all segments for a few seconds when the ignition key is turned to "ON". The tachometer momentarily goes from the minimum to the maximum, then goes back from the maximum to the minimum reading to check its operation. If any meter instruments or tachometer does not operate or display correctly, have it checked by an authorized Kawasaki dealer.

### Tachometer Gauge:

The tachometer shows the engine speed in revolutions per minute (r/min, rpm). On the right side of the tachometer face is a portion called the "red zone". Engine r/min (rpm) in the red zone is above maximum recommended engine speed and is also above the range for good performance.

### NOTE

- *This motorcycle is equipped with the engine speed limiter to prevent the excessive high engine speed. When operating this limiter, the segments of the tachometer indicate the different engine speed and stops at about 5000 r/min (rpm) for the ignition control, but this operation is not a failure.*

### NOTICE

**Engine r/min (rpm) should not be allowed to enter the red zone; operation in the red zone will overstress the engine and may cause serious engine damage.**

### Speedometer :

The speedometer shows the speed of the vehicle in digital values.



### Odometer/Trip Meter AB/Fuel Warning Message (ODO/TRIP AB):

This meter displays the odometer, the trip meter AB, and the fuel warning message.

The odometer and the trip meter AB can be shifted pushing the MODE button.

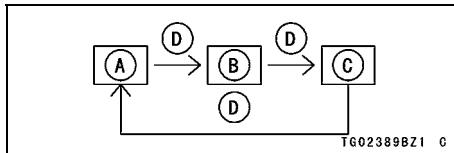

- A. Odometer
- B. Trip meter A
- C. Trip meter B
- D. MODE Button

### NOTE

- Do not shift the odometer/trip meter while riding for safe operation.

### Odometer -

The odometer shows the total distance in kilometers or miles that the vehicle has been ridden. This meter cannot be reset.

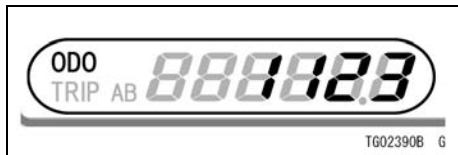

### NOTE

- The data is maintained even if the battery is disconnected.
- When the figures come to 999999, they are stopped and locked.

### Trip Meters A/B -

The trip meter shows the distance in kilometers or miles traveled since it was last reset to zero.

To reset the trip meter:

## 24 GENERAL INFORMATION

- Push the MODE button to display the trip meter A or B.
- Push the RESET button and hold it in.
- After two second, the figure display turns to 0.0, and then starts counting when the vehicle is operated. The meter counts until it is next reset.

### NOTE

- *The data is maintained by the back-up power if the ignition key is turned off.*
- *When the trip meter reaches 999.9 (TRIP A) or 9999.9 (TRIP B) while riding, the meter resets to 0.0 and continues counting.*
- *When the battery is disconnected, the meter display resets to 0.0.*

### Mile/Km Display:

Mile/Km Display can alternate between English and metric modes (mph and km/h) in the meter unit. Make sure that km/h or mph according to local regulations is correctly displayed before riding.

**NOTE**

○ Do not operate the vehicle with the meter unit displaying in the wrong unit (km/h or mph). Shift the km/h-mph display in the meter unit as follows.

- Display the odometer.
- The km/h-mph display shifts by pushing the RESET button while the MODE button pushed in.

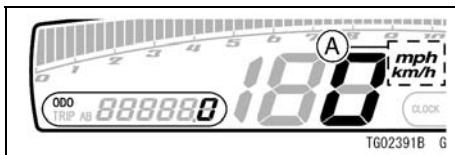
**A. Km/h-Mph Display**

- The km/h/mph display shifts as follows.

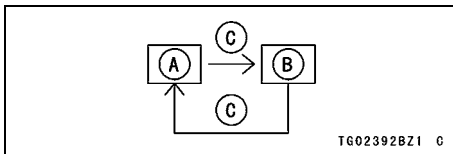
**A. Km/h****B. Mph****C. Push RESET Button with MODE Button in****NOTE**

○ The data is maintained even if the battery is disconnected.

**Clock:**

To adjust hours and minutes:

- Turn the ignition key to "ON".
- Push the RESET button for more than two seconds. Both the hour and minute displays start flashing.

## 26 GENERAL INFORMATION



- Push the RESET button. The hour display only flashes. Push the MODE button to advance the hours.



- Push the RESET button. The hour display stops flashing and the minute display starts flashing. Push the MODE button to advance the minutes.

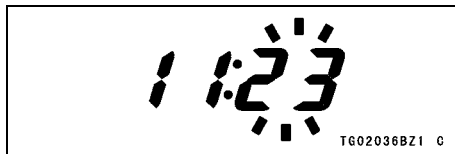

- Push the RESET button. Both the hour and minute displays start flashing again.
- Push the MODE button. The displays stop flashing and the clock starts working.

### NOTE

- *Pushing the MODE button momentarily advances the hour or minute step by step. Pushing and holding the button advances the hour or minute continuously.*
- *The clock works normally from the back-up power while the ignition switch is turned off.*

- *When the battery is disconnected, the clock resets to 1:00 and starts working again when the battery is connected.*

### Indicator/Warning Light:

**N** : When the transmission is in neutral, the neutral indicator light is lit.

↔ : When the turn signal switch is turned to left or right, the turn signal indicator light flashes on and off.

☰ : When the headlight is on high beam, the high beam indicator light is lit.

 : The coolant temperature warning light goes on when the ignition key is turned to "ON" and goes off soon after ensuring that its circuit function properly. The warning light also goes on whenever the coolant temperature

rises too high when the motorcycle is in operation. If it stays on, stop the engine and check the coolant level in the reserve tank after the engine cools down.

## NOTICE

**Do not let the engine continue running when the warning light goes on. Prolonged engine operation will result in severe damage from overheating.**

### Warning/Indicator Lights:

 : The fuel level warning indicator light goes on and "FUEL" flashes in the digital meter, when approximately 2.3 L(0.6 US gal) of usable fuel remains. Refuel at the earliest opportunity when the fuel level indicator light goes on and "FUEL" flashes.

## 28 GENERAL INFORMATION

When vehicle stands with side stand, warning message cannot show the amount of fuel in the fuel tank exactly. Stand upright the vehicle to check the fuel level.



### A. "Fuel Warning Message"

**FI:** The fuel injection (FI) indicator light in the tachometer goes on when the ignition key is turned to "ON" and goes off soon after ensuring that its circuit functions properly. The indicator light also goes on whenever the troubles occur in digital fuel injection system (DFI). If the indicator light comes on, have the

DFI system checked by an authorized Kawasaki dealer,  
When the indicator light flashes, first turn the ignition key to "OFF" and then back to "ON".

## Key

This motorcycle has a combination key, which is used for the ignition switch/steering lock, helmet hook, and fuel tank cap.

Blank keys are available at your Kawasaki dealers. Ask your dealer to make any additional spare keys you may need, using your original key as a master.

## Ignition Switch/Steering Lock

This is a three-position, key-operated switch. The key can be removed from the switch when it is in the OFF or LOCK position.

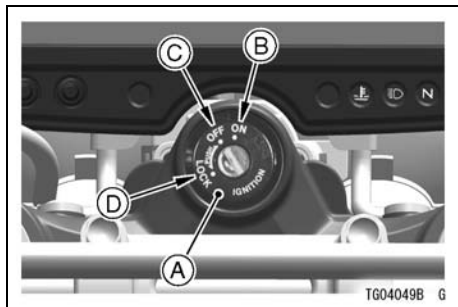

- A. Ignition Switch/Steering Lock
- B. ON position
- C. OFF position
- D. LOCK position

### 30 GENERAL INFORMATION

<b>ON</b>	Engine on. All electrical equipment can be used.
<b>OFF</b>	Engine off. All electrical circuits off.
<b>LOCK</b>	Steering locked. Engine off. All electrical circuits off.

#### **NOTE**

- *The headlight and taillight are on whenever the ignition key is in the ON position. To avoid battery discharge, always start the engine immediately after turning the ignition key to "ON".*

#### **To lock the steering:**

1. Turn the handlebar fully to the left.

2. For locking, push down the key in the OFF position and turn it to Lock position.
3. Pull the key out.

#### **NOTE**

- *If the steering is hard to lock, turn the handlebar slightly to the left or the right.*



## Right Handlebar Switches

### Engine Stop Switch:

In addition to the ignition switch, the engine stop switch must be in the  position for the motorcycle to operate.

The engine stop switch is for emergency use. If required, move the switch to the  position.

### NOTE

*○ Although the engine stop switch stops the engine, it does not turn off all the electrical circuits. Ordinarily, the ignition switch should be used to stop the engine.*



### Starter Button:

The starter button operates the electric starter when the transmission is in neutral.

Refer to the Starting the Engine section of the "How to Ride the Motorcycle" chapter for starting instructions.

### Headlight Switch:

The headlight switch is on the right handlebar.

○	The headlight is off with the switch in the ○ position.
	The city, tail, and meter lights come on if the switch is pushed to this position with the ignition switch in the ON position.
	The head, city, tail, and meter lights come on if the switch is pushed forward to this position with the ignition switch in the ON position.

## 32 GENERAL INFORMATION

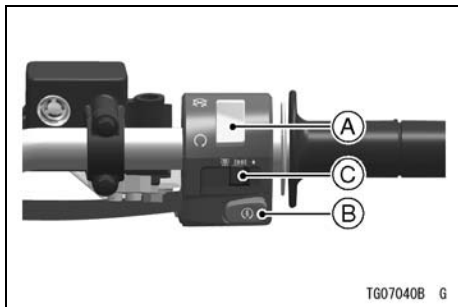

- A. Engine Stop Switch
- B. Starter Button
- C. Headlight Switch

### Left Handlebar Switches Dimmer Switch:

High or low beam can be selected with the dimmer switch. When the headlight is on high beam , the high beam indicator light is lit.

High beam.....(  )

Low beam.....(  )

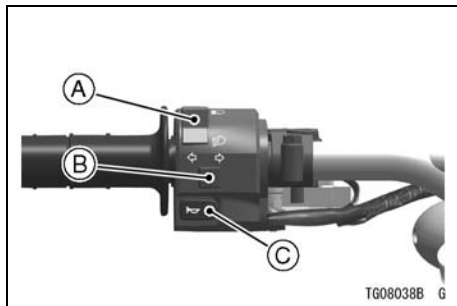

- A. Dimmer Switch
- B. Turn Signal Switch
- C. Horn Button

**Turn Signal Switch:**

When the turn signal switch is turned to the left  $\leftarrow$  or right  $\rightarrow$ , the corresponding turn signals flash on and off.

To stop flashing, push the switch in.

**Horn Button:**

When the horn button is pushed, the horn sounds.

**Fuel Tank Cap**

To open the fuel tank cap, insert the ignition key into the fuel tank cap, turn the key to the right.

To close the cap, push it down into place with the key inserted. The key can be removed by turning it to the left to the original position.

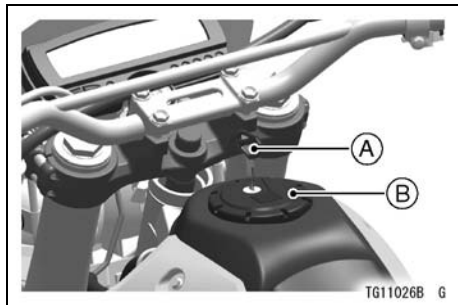

- A. Ignition Key
- B. Fuel Tank Cap

## 34 GENERAL INFORMATION

### NOTE

- *The fuel tank cap cannot be closed without the key inserted, and the key cannot be removed unless the cap is locked properly.*
- *Do not push on the key to close the cap, or the cap cannot be locked.*

### Fuel

#### Fuel Requirements:

Your Kawasaki engine is designed to use only unleaded gasoline with a minimum octane rating shown below. Never use gasoline with an octane rating lower than the minimum specified by Kawasaki to prevent severe engine damage.

The octane rating of a gasoline is a measure of its resistance to detonation or “knocking”. The term commonly used to describe a gasoline’s octane rating is the Research Octane Number (RON).

**NOTICE**

**Do not use leaded gasoline, as this will destroy the catalytic converter. (For further information, refer to the “Catalytic Converter” section in the “How to Ride the Motorcycle” chapter.)**

**NOTICE**

**If engine “knocking” or “pinging” occurs, use a different brand of gasoline of a higher octane rating. If this condition is allowed to continue, it can lead to severe engine damage. Gasoline quality is important. Fuels of low quality or not meeting standard industry specifications may result in unsatisfactory performance. Operating problems that result from the use of poor quality or no recommended fuel may not be covered under your warranty.**

*Fuel Type and Octane Rating*

Use clean, fresh unleaded gasoline and an octane rating equal to or higher than that shown in the table.

## 36 GENERAL INFORMATION

Fuel Type	Unleaded Gasoline
Minimum Octane Rating	Research Octane Number (RON) 91

### NOTICE

**Do not use an E10 fuel\*, or any fuel with an ethanol volume content more than 5 % in this vehicle. It has not been tested and certified for use with such fuels. Damage to the engine and fuel system, or engine starting and/or performance problems may result from the use of improper fuel.**

\*E10 means fuel containing up to 10% ethanol as specified by European directive.

### Filling the Tank:

Avoid filling the tank in the rain or where heavy dust is blowing so that the fuel does not get contaminated.

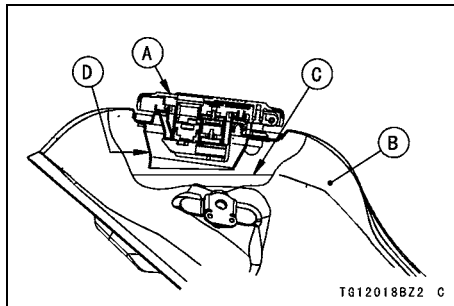

- A. Tank Cap
- B. Fuel Tank
- C. Top Level
- D. Filler Neck

** WARNING**

Gasoline is extremely flammable and can be explosive under certain conditions. Turn the ignition key to “OFF”. Do not smoke. Make sure the area is well ventilated and free from any source of flame or sparks; this includes any appliance with a pilot light. Never fill the tank so the fuel level rises into the filler neck. If the tank is overfilled, heat may cause the fuel to expand and overflow through the vents in the tank cap. After refueling, make sure the fuel tank cap is closed securely. If gasoline is spilled on the fuel tank, wipe it off immediately.

**NOTICE**

Certain ingredients in gasoline may cause paint fading or damage. Be extra careful not to spill fuel during refueling.

## 38 GENERAL INFORMATION

### Stand

The motorcycle is equipped with a side stand.

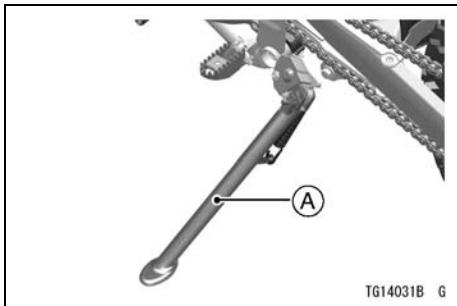

A. Side Stand

### NOTE

- When using the side stand, turn the handlebar to the left.

Whenever the side stand is used, make it a practice to kick the stand fully up before sitting on the motorcycle.

### NOTE

- The motorcycle is equipped with a side stand switch. This switch is designed so that the engine dose not start if the transmission is in gear and the side stand is down.



## Helmet Hook

Helmet can be secured to the motorcycle using the helmet hook.

The helmet hook can be unlocked by inserting the ignition key into the lock, and turning the key to the right.

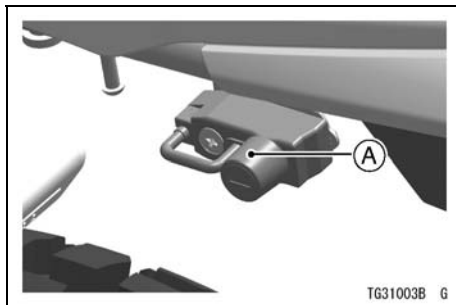

A. Helmet Hook

## WARNING

**Riding with a helmet attached to the hook could cause an accident by distracting the operator or interfering with normal vehicle operation. Do not ride the motorcycle with a helmet attached to the hook.**

## 40 GENERAL INFORMATION

### Tool Kit Bag/Tool Kit

The tool kit is stored in the tool kit bag.

The kit contains tools that can be helpful in making roadside repairs, adjustments, and some maintenance procedures explained in this manual.

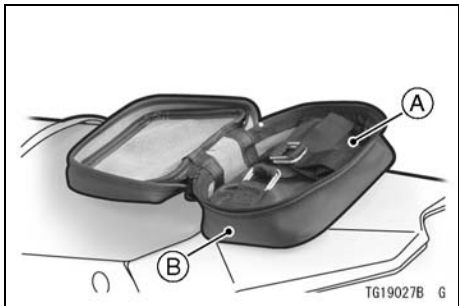

- A. Tool Kit
- B. Tool Kit Bag

### Seat

#### *Seat Removal*

- Remove the mounting bolts.

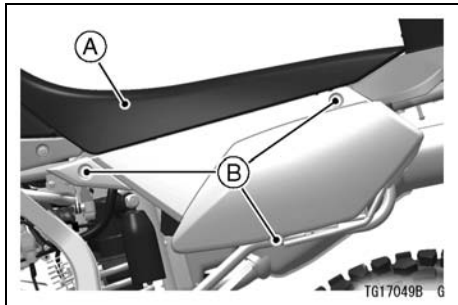

- A. Seat
- B. Mounting Bolts

- Remove the seat band and pull the seat up and to the rear.

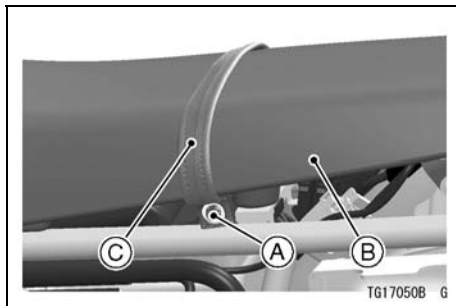

- A. Bolt
- B. Seat
- C. Tandem Band

### *Seat Installation*

- Align the front hook with the front receiver and slide the seat forward.

- Slide the seat forward so that the center hook and the center receiver engages.

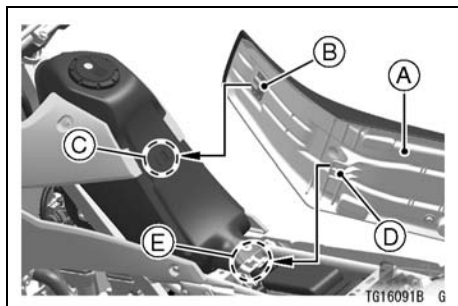

- A. Seat
- B. Front Hook
- C. Front Receiver
- D. Center Hook
- E. Center Receiver

- Tighten the tandem band bolts.
- Pull up the rear end of the seat to make sure it is securely tightened.
- Reinstall the parts removed.

---

## BREAK-IN

---

The first 1 600 km (1 000 mi) that the motorcycle is ridden is designated as the break-in period. If the motorcycle is not used carefully during this period, you may very well end up with a "broken down" instead of a "broken in" motorcycle after a few thousand kilometers.

The following rules should be observed during the break-in period.

- The table shows maximum recommended engine speed during the break-in period.

Distance traveled	Maximum engine speed
0 ~ 800 km (0 ~ 500 mi)	4 000 r/min (rpm)
800 ~ 1 600 km (500 ~ 1 000 mi)	6 000 r/min (rpm)

- Do not start moving or race the engine immediately after starting it, even if the engine is already warm. Run the engine for two or three minutes at idle speed to give the oil a chance to work up into all the engine parts.
- Do not race the engine while the transmission is in neutral.

 **WARNING**

**New tires are slippery and may cause loss of control and injury. A break-in period of 160 km (100 miles) is necessary to establish normal tire traction. During break-in, avoid sudden and maximum braking and acceleration, and hard cornering.**

In addition to the above, at 1 000 km (600 mi) it is extremely important that the owner have the initial maintenance service performed by an authorized Kawasaki dealer.

---

## HOW TO RIDE THE MOTORCYCLE

---

### Starting the Engine

- Check that the engine stop switch is in the  position.

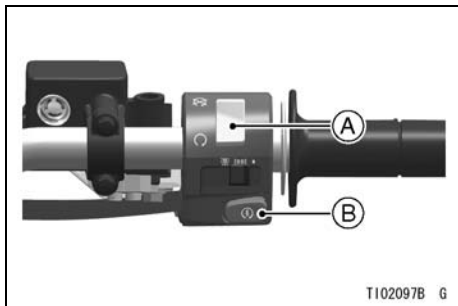

- A. Engine Stop Switch
- B. Starter Button

- Turn the ignition key to "ON".
- Make certain the transmission is in neutral.

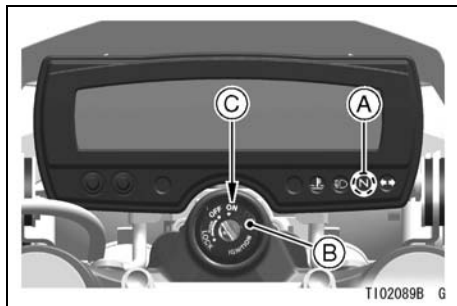

- A. Neutral Indicator Light
- B. Ignition Switch
- C. ON position

### NOTE

- *The motorcycle is equipped with a vehicle-down sensor, which causes the engine to stop automatically when the motorcycle falls down. After righting the motorcycle, first turn*

*the ignition key to “OFF” and then back to “ON” before starting the engine.*

- Leaving the throttle completely closed, push the starter button.

## NOTICE

**Do not operate the starter continuously for more than 5 seconds or the starter will overheat and the battery power will drop temporarily. Wait 15 seconds between each operation of the starter to let it cool and the battery power recover.**

## NOTE

- *The motorcycle is equipped with a starter lockout switch. This switch is*

*designed so that the engine does not start if the transmission is in gear and the side stand is down. However, the engine can be started if the clutch lever is pulled and the side stand is fully up.*

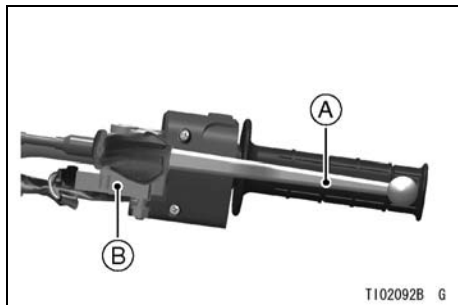

**A. Clutch Lever**  
**B. Starter Lockout Switch**

T102092B G

***NOTICE***

**Do not let the engine idle longer than five minutes, or engine overheating and damage may occur.**

**Jump Starting**

If your motorcycle battery is "run down", it should be removed and charged. If this is not practical, a 12 volt booster battery and jumper cables may be used to start the engine.



**⚠ DANGER**

Battery acid generates hydrogen gas which is flammable and explosive under certain conditions. It is present within a battery at all times, even in a discharged condition. Keep all flames and sparks (cigarettes) away from the battery. Wear eye protection when working with a battery. In the event of battery acid contact with skin, eyes, or clothing, wash the affected areas immediately with water for at least five minutes. Seek medical attention.

*Connecting Jumper Cables*

- Remove the left side cover.
- Make sure the ignition switch is turned "OFF".

- Connect a jumper cable from the positive (+) terminal of the booster battery to the positive (+) terminal of the motorcycle battery.

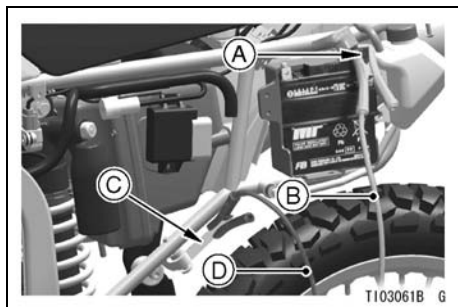

- A. Motorcycle Battery Positive (+) Terminal  
 B. From Booster Battery Positive (+) Terminal  
 C. Unpainted Metal Surface  
 D. From Booster Battery Negative (-) Terminal

## 48 HOW TO RIDE THE MOTORCYCLE

- Connect another jumper cable from the negative (-) terminal of the booster battery to your motorcycle foot peg or other unpainted metal surface. Do not use the negative (-) terminal of the battery.

### **DANGER**

**Batteries contain sulfuric acid that can cause burns and produce hydrogen gas which is highly explosive. Do not make this last connection at the fuel system or battery. Take care not to touch the positive and negative cables together, and do not lean over the battery when making this last connection. Do not connect to a frozen battery. It could explode. Do not reverse polarity by connecting positive (+) to negative (-), or a battery explosion and serious damage to the electrical system may occur.**

- Follow the standard engine starting procedure.

**NOTICE**

**Do not operate the starter continuously for more than 5 seconds or the starter will overheat and the battery power will drop temporarily. Wait 15 seconds between each operation of the starter to let it cool and the battery power recover.**

- After the engine has started, disconnect the jumper cables. Disconnect the negative (-) cable from the motorcycle first.
- Reinstall the parts removed.

**Moving Off**

- Check that the side stand is up.
- Pull in the clutch lever.
- Shift into 1st gear.
- Open the throttle a little, and start to let out the clutch lever very slowly.
- As the clutch starts to engage, open the throttle a little more, giving the engine just enough fuel to keep it from stalling.

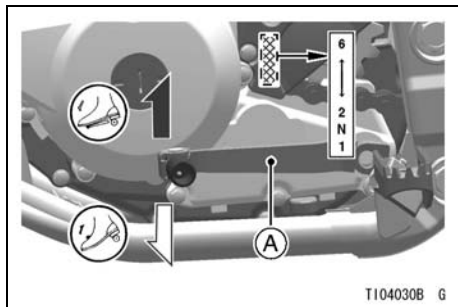

**A. Shift Pedal**

### NOTE

- *The motorcycle is equipped with a side stand switch. This switch is designed so that the engine does not start if the transmission is in gear and the side stand is down.*

### Shifting Gears

- Close the throttle while pulling in the clutch lever.
- Shift into the next higher or lower gear.

### **WARNING**

**Downshifting to a lower gear at high speed causes engine rpm to increase excessively, potentially damaging the engine and it may also cause the rear wheel to skid and cause an accident. Downshifting should be done below 5 000 rpm for each gear.**

- Open the throttle part way, while releasing the clutch lever.

## Braking

- Close the throttle completely, leaving the clutch engaged (except when shifting gears) so that the engine will help slow down the motorcycle.
- Shift down one gear at a time so that you are in 1st gear when you come to a complete stop.
- When stopping, always apply both brakes at the same time. Normally the front brake should be applied a little more than the rear. Shift down or fully disengage the clutch as necessary to keep the engine from stalling.
- Never lock the brakes, or it will cause the tires to skid. When turning a corner, it is better not to brake at all. Reduce your speed before you get into the corner.

- For emergency braking, disregard downshifting, and concentrate on applying the brakes as hard as possible without skidding.

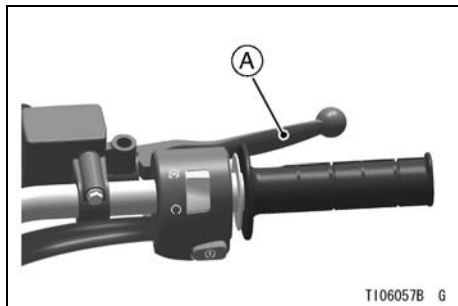

A. Front Brake Lever

## 52 HOW TO RIDE THE MOTORCYCLE

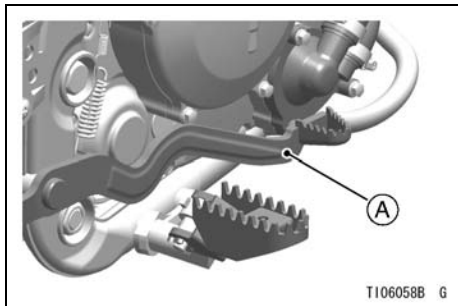

**A. Rear Brake Pedal**

### **Stopping the Engine**

- Close the throttle completely.
- Shift the transmission into neutral.
- Turn the ignition key to "OFF".
- Support the motorcycle on a firm level surface with the side stand.
- Lock the steering.

## Stopping the Motorcycle in an Emergency

Your Kawasaki Motorcycle has been designed and manufactured to provide you optimum safety and convenience. However, in order to fully benefit from Kawasaki's safety engineering and craftsmanship, it is essential that you, the owner and operator, properly maintain your motorcycle and become thoroughly familiar with its operation. Improper maintenance can create a dangerous situation known as throttle failure. Two of the most common causes of throttle failure are:

1. An improperly serviced or clogged air cleaner may allow dirt and dust to enter the throttle body and stick the throttle open.
2. During removal of the air cleaner, dirt is allowed to enter and jam the fuel injection system.

In an emergency situation such as throttle failure, your vehicle may be stopped by applying the brakes and disengaging the clutch. Once this stopping procedure is initiated, the engine stop switch may be used to stop the engine. If the engine stop switch is used, turn off the ignition switch after stopping the motorcycle.

## Parking

- Shift the transmission into neutral and turn the ignition key to "OFF".
- Support the motorcycle on a firm, level surface with the side stand.

### **NOTICE**

**Do not park on a soft or steeply inclined surface, or the motorcycle may fall over.**

- If parking inside a garage or other structure, be sure it is well ventilated and the motorcycle is not close to any source of flame or sparks; this includes any appliance with a pilot light.

### **WARNING**

**The muffler and exhaust pipe are very hot while the engine is running and just after the engine stops. This can ignite a fire, resulting in property damage or severe personal injury.**

**Do not idle or park your vehicle in an area where flammable materials such as grasses or dry leaves may contact with muffler or exhaust pipe.**



 **WARNING**

**Gasoline is extremely flammable and can be explosive under certain conditions, creating the potential for serious burns. Turn the ignition switch “OFF”. Do not smoke. Make sure the area is well ventilated and free from any source of flame or sparks; this includes any appliance with a pilot light.**

**Never fill the tank completely to the top. If the tank is filled completely to the top, heat may cause the fuel to expand and overflow through the vents in the tank cap. After refueling, make sure the tank cap is closed securely.**

**If gasoline is spilled on the fuel tank, wipe it off immediately.**

- Lock the steering to help prevent theft.

### Catalytic Converter

This motorcycle is equipped with a catalytic converter in the exhaust system. Platinum and rhodium in the converter react with carbon monoxide, hydrocarbons and nitrogen oxides to convert them into carbon dioxide, water, nitrogen and oxygen resulting in much cleaner exhaust gases to be discharged into the atmosphere.

For proper operation of the catalytic converter, the following cautions must be observed.

### WARNING

**The muffler and exhaust pipe are very hot while the engine is running and just after the engine stops. This can ignite a fire, resulting in property damage or severe personal injury.**

**Do not idle or park your vehicle in an area where flammable materials such as grasses or dry leaves may contact with muffler or exhaust pipe.**

- Use only unleaded gasoline. Never use leaded gasoline. Leaded gasoline significantly reduces the capability of the catalytic converter.
- Do not operate the vehicle with the engine or any one cylinder misfiring. Under these conditions unburned air/fuel mixture flowing out of engine excessively accelerates reaction in

the converter allowing the converter to overheat and become damaged when the engine is hot, or reduces converter performance when the engine is cold.

## **Safe Riding Technique**

The points given below are applicable for everyday motorcycle use and should be carefully observed for safe and effective vehicle operation.

**For safety, eye protection and a helmet are strongly recommended. Gloves and suitable footwear should also be used for added protection in case of a mishap.**

**A motorcycle does not provide the impact protection of an automobile, so defensive riding in addition to wearing protective apparel is extremely important. Do not let protective apparel give you a false sense of security.**

**When riding always keep both hands on the handlebars and both**

**feet on the footpegs. Removing your hands from the handlebars or feet from the footpegs while riding can be hazardous. If you remove even one hand or foot, you can reduce your ability to control the motorcycle.**

**Before changing lanes, look over your shoulder to make sure the way is clear. Do not rely solely on the rear view mirror; you may misjudge a vehicle's distance and speed, or you may not see it at all.**

**In general your actions should be smooth as sudden acceleration,**

**braking or turning may cause loss of control, especially when riding in wet conditions or on loose roadway surfaces, when the ability to maneuver will be reduced.**

**When going up steep slopes, shift to a lower gear so that there is plenty of power to spare rather than overloading the engine.**

**When applying the brakes, use both the front and rear brakes. Applying only one brake for sudden braking may cause the motorcycle to skid and lose control.**

**When going down long slopes, control vehicle speed by closing the throttle. Use the front and rear brakes for auxiliary braking.**

**In wet conditions, rely more on the throttle to control vehicle speed and less on the front and rear brakes. The throttle should also be used judiciously to avoid skidding the rear wheel from too rapid acceleration or deceleration.**

**Riding at the proper rate of speed and avoiding unnecessarily fast acceleration are important not only for safety and low fuel consumption but also for long vehicle life and quieter operation.**

**On rough roads, exercise caution, slow down, and grip the fuel tank with the knees for better stability.**

**When quick acceleration is necessary as in passing, shift to a lower gear to obtain the necessary power.**

## **60 SAFE OPERATION**

**Do not downshift at too high an r/min (rpm) to avoid damage to the engine from overrevving.**

**Avoiding unnecessary weaving is important to the safety of both the rider and other motorists.**

## Daily Safety Checks

Check the following items each day before you ride. The time required is minimal, and habitual performance of these checks will help ensure you a safe, reliable ride.

If any irregularities are found during these checks, refer to the Maintenance and Adjustment chapter or see your dealer for the action required to return the motorcycle to a safe operating condition.

### **WARNING**

**Failure to perform these checks before operation may result in serious damage or an accident. Always perform daily safety checks before operation.**

### **DANGER**

**Exhaust gas contains carbon monoxide, a colorless, odorless poisonous gas.  
Inhaling carbon monoxide can cause serious brain injury or death.  
Do not run the engine in enclosed areas. Operate only in a well-ventilated area.**

Fuel ..... Adequate supply in tank, no leaks.

Engine oil ..... Oil level between level lines.

## 62 SAFE OPERATION

Tires ..... Air pressure (when cold):

Front	---	150 kPa (1.50 kgf/cm <sup>2</sup> , 22 psi)
Rear	Up to 97.5 kg (215 lb) Load	150 kPa (1.50 kgf/cm <sup>2</sup> , 22 psi)
	97.5 ~ 181 kg (215 ~ 399 lb) Load	175 kPa (1.75 kgf/cm <sup>2</sup> , 25 psi)

Install the air valve cap.

Drive chain ..... Slack 35 ~ 45 mm (1.4 ~ 1.8 in.).

Lubricate if dry

Nuts, bolts, fasteners .. Check that steering and suspension components, axles, and all controls are properly tightened or fastened.

Steering ..... Action smooth but not loose from lock to lock. No binding of control cables.

Brakes ..... Brake pad wear: Lining thickness more than 1 mm (0.04 in.) left.

No brake fluid leakage.

Throttle ..... Throttle grip play 2 ~ 3 mm (0.08 ~ 0.12 in.).

Clutch ..... Clutch lever play 2 ~ 3 mm (0.08 ~ 0.12 in.).

Clutch lever operates smoothly.

Coolant ..... No coolant leakage

Coolant level between level lines (when engine is cold).



- Electrical equipment ... All lights (Head, Tail/Brake, Turn Signal, Warning/Indicator) and horn work.
- Engine stop switch ..... Stops engine.
- Side stands ..... Return to its fully up position by spring tension.  
Return springs not weak or not damaged.

## **Additional Considerations for Off Road Operation**

**Brakes:** The importance of reliable brakes is obvious. Check to see that they are correctly adjusted and functioning properly.

**Steering:** Looseness in the steering can cause loss of control. Check to see that the handlebar turns freely but has no play.

**Tires:** Due to the extra stress to the tires on rough roads, be sure to examine their overall condition, and inflate to the proper pressure.

**Drive Chain:** When not adjusted properly, the severe stress on rough roads can cause damage to the sprockets and cause the chain to be thrown. Examine the chain slack and alignment, and lubricate if necessary.

**Fuel:** Have sufficient fuel for the high fuel consumption on rough roads.

**Engine Oil:** To avoid seizure and resulting loss of control, make certain the oil level is at the upper level line.

**Coolant:** To avoid engine overheating, check that the coolant level is at the upper level line.

**Miscellaneous:** Check to see that the electrical equipment is functioning properly, all nuts and bolts are tight, and all safety related parts are in good condition.

---

## MAINTENANCE AND ADJUSTMENT

---

The maintenance and adjustments outlined in this chapter must be carried out in accordance with the Periodic Maintenance Chart to keep the motorcycle in good running condition. **The initial maintenance is vitally important and must not be neglected.**

With a basic knowledge of mechanics and the proper use of tools, you should be able to carry out many of the maintenance items described in this chapter. If you lack proper experience or doubt your ability, all adjustment, maintenance, and repair work should be completed by a qualified technician.

Please note that Kawasaki cannot assume any responsibility for damage resulting from incorrect or improper adjustment done by the owner.

## 66 MAINTENANCE AND ADJUSTMENT

### Periodic Maintenance Chart

K: Should be serviced by an authorized Kawasaki dealer.



\*: For higher odometer readings, repeat at the frequency interval established here.

†: Replace, add, adjust, or torque if necessary.



#: Service more frequently when operating in severe conditions: dusty, wet, muddy, high speed, or frequent starting/stopping.

#### 1. Periodic Inspection (Engine Related Items)

Operation (Engine Items)	Frequency	*Odometer Reading km × 1000 ( mile × 1000)							See Page
	Whichever comes first ↓	1 (0.6)	6 (3.75)	12 (7.5)	18 (11.25)	24 (15)	30 (18.75)	36 (22.5)	
Air cleaner element - clean	Every			●		●		●	93
<b>K</b> Valve clearance - inspect				●		●		●	89

Operation (Engine Items)	Frequency	Whichever comes first  							*Odometer Reading km x 1000 ( mile x 1000)	See Page
	Ev-ery	1 (0.6)	6 (3.75)	12 (7.5)	18 (11.25)	24 (15)	30 (18.75)	36 (22.5)		
Throttle control system (play, smooth return, no drag) - inspect	year	●		●		●		●	96	
Idle speed - inspect		●		●		●		●	98	
<b>K</b> Fuel leak (fuel hose and pipe) - inspect	year	●		●		●		●	—	
<b>K</b> Fuel hoses and pipe damage - inspect	year	●		●		●		●	—	
<b>K</b> Fuel hoses and pipe installation condition - inspect	year	●		●		●		●	—	
Coolant level - inspect		●		●		●		●	85	
Coolant leak - inspect	year	●		●		●		●	83	

## 68 MAINTENANCE AND ADJUSTMENT

Operation (Engine Items)	Frequency	Whichever comes first  							*Odometer Reading km x 1000 ( mile x 1000)	See Page
	Ev- ery	1 (0.6)	6 (3.75)	12 (7.5)	18 (11.25)	24 (15)	30 (18.75)	36 (22.5)		
Radiator hose damage - inspect	year	●		●		●		●	83	
Radiator hoses installation condition - inspect	year	●		●		●		●	83	
<b>K</b> Air suction system damage - inspect				●		●		●	89	

**2. Periodic Inspection (Chassis Related Items)**

Frequency	Whichever comes first →								*Odometer Reading km x 1000 ( mile x 1000)	See Page
	↓	1 (0.6)	6 (3.75)	12 (7.5)	18 (11.25)	24 (15)	30 (18.75)	36 (22.5)		
<b>Operation (Chassis Items)</b>	<b>Ev- ery</b>									
<b>Clutch and drive train:</b>										
Clutch operation (play, engagement, disengagement) - inspect		●		●		●		●		99
Drive chain lubrication condition - inspect #	every 600 km (400 mile)								108	
Drive chain slack - inspect #	every 1 000 km (600 mile)								103	
Drive chain wear - inspect #				●		●		●	106	
<b>K</b> Drive chain guide wear - inspect				●		●		●	-	







## 72 MAINTENANCE AND ADJUSTMENT

Frequency	Whichever comes first →								*Odometer Reading km x 1000 ( mile x 1000)	See Page
	↓	1 (0.6)	6 (3.75)	12 (7.5)	18 (11.25)	24 (15)	30 (18.75)	36 (22.5)		
Operation (Chassis Items)	Ev-ery									
Brake light switch operation - inspect		●	●	●	●	●	●	●	113	
<b>Suspensions:</b>										
Front forks/rear shock absorber operation (damping and smooth stroke) - inspect				●		●		●	115/ 117	
Front forks/rear shock absorber oil leak - inspect	year			●		●		●	115/ 117	
<b>K</b> Uni-trak rocker arm bearings - lubricate						●			-	
<b>K</b> Uni-trak rocker arm operation - inspect				●		●		●	-	

Frequency	Whichever comes first →								*Odometer Reading km x 1000 ( mile x 1000)	See Page
	↓	1 (0.6)	6 (3.75)	12 (7.5)	18 (11.25)	24 (15)	30 (18.75)	36 (22.5)		
Operation (Chassis Items)	Ev-ery									
K Uni-trak tie rods operation - inspect				●		●		●	—	
K Uni-trak tie rods bearings - lubricate						●			—	
K Swing arm pivot - lubricate						●			—	
<b>Steering system:</b>										
K Steering play - inspect	year	●		●		●		●	—	
K Steering stem bearings - lubricate	2 years					●			—	
<b>Electrical system:</b>										
Lights and switches operation - inspect	year			●		●		●	—	

## 74 MAINTENANCE AND ADJUSTMENT

Frequency	Whichever comes first → ↓	*Odometer Reading km x 1000 ( mile x 1000)							See Page	
		Ev- ery	1 (0.6)	6 (3.75)	12 (7.5)	18 (11.25)	24 (15)	30 (18.75)		36 (22.5)
Headlight aiming - inspect	year			●			●		●	129
Side stand switch operation - inspect	year			●			●		●	—
Engine stop switch operation - inspect	year			●			●		●	—
<b>Chassis:</b>										
<b>K</b> Chassis parts - lubricate	year			●			●		●	—
<b>K</b> Bolts and nuts tightness - inspect		●		●			●		●	—

## 3. Periodic Replacement

Change/Replacement Item	Frequency	*Odometer Reading km x 1000 ( mile x 1000)					See Page
	Whichever comes first ↓ Every	1 (0.6)	12 (7.5)	24 (15)	36 (22.5)	48 (30)	
Air cleaner element # - replace	2 year						91
Engine oil # - change	year	●	●	●	●	●	79
Oil filter - replace	year	●	●	●	●	●	79
<b>K</b> Fuel hoses - replace	4 years					●	–
<b>K</b> Coolant - change	3 years				●		87
<b>K</b> Radiator hoses and O-rings - replace	3 years				●		–
<b>K</b> Brake hoses - replace	4 years					●	–
<b>K</b> Brake fluid (front and rear) - change	2 years			●		●	112

## 76 MAINTENANCE AND ADJUSTMENT

Change/Replacement Item	Frequency	Whichever comes first → *Odometer Reading km × 1000 ( mile × 1000)					See Page
	Every	1 (0.6)	12 (7.5)	24 (15)	36 (22.5)	48 (30)	
<b>K</b> Rubber parts of master cylinder and caliper - replace	4 years					●	–
Spark plug - replace			●	●	●	●	87

## Engine Oil

In order for the engine, transmission, and clutch to function properly, maintain the engine oil at the proper level, and change the oil and oil filter in accordance with the Periodic Maintenance Chart. Not only do dirt and metal particles collect in the oil, but the oil itself loses its lubricative quality if used too long.

### **WARNING**

**Motorcycle operation with insufficient, deteriorated, or contaminated engine oil will cause accelerated wear and may result in engine or transmission seizure, accident, and injury. Check the oil level before each ride and change the oil according to the periodic maintenance chart in the owner's manual.**

### *Oil Level Inspection*

- Situate the motorcycle so that it is perpendicular to the ground.
- If the oil has just been changed, start the engine and run it for several minutes at idle speed. This fills the oil filter with oil. Stop the engine, then wait several minutes until the oil settles.

### **NOTICE**

**Racing the engine before the oil reaches every part can cause engine seizure.**

- If the motorcycle has just been used, wait several minutes for all the oil to drain down.
- Check the engine oil level through the oil level gauge in the lower right side of the engine. The oil level

## 78 MAINTENANCE AND ADJUSTMENT

should come up between the upper and lower level lines next to the gauge.

- If the oil level is too high, remove the excess oil through the oil filler opening using a syringe or some other suitable device.
- If the oil level is too low, add the oil to reach the correct level. Use the same type and brand of oil that is already in the engine.

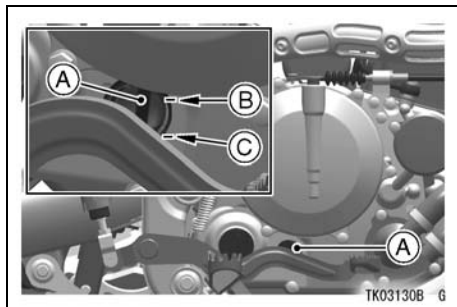

- A. Oil Level Gauge
- B. Upper Level Line
- C. Lower Level Line



*Oil and/or Oil Filter Change*

- Warm up the engine thoroughly, and then stop it.
- Set the motorcycle up on its side stand.
- Place an oil pan beneath the engine.
- Remove the engine oil drain plug.

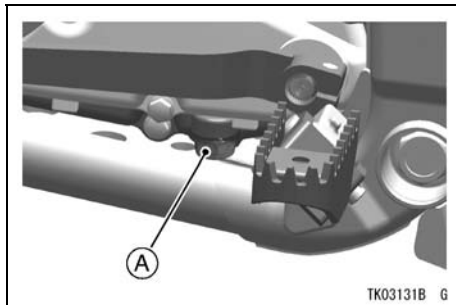

A. Drain Plug

- Let the oil completely drain with the motorcycle perpendicular to the ground.

**⚠ WARNING**

**Motor oil is a toxic substance. Dispose of used oil properly. Contact your local authorities for approved disposal methods or possible recycling.**

## 80 MAINTENANCE AND ADJUSTMENT

- If the oil filter is to be changed, remove the oil filter cover bolts and take off the cover with O-ring.

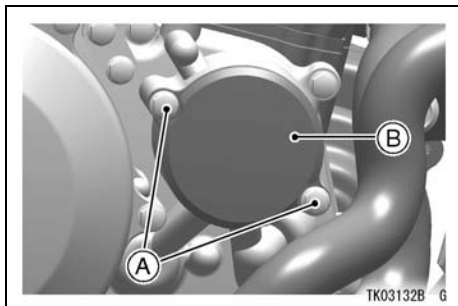

- A. Bolts
- B. Oil Filter Cover

- Replace the element with a new one.

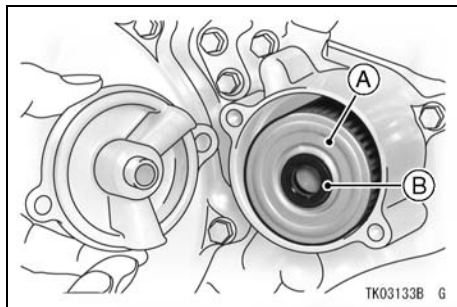

- A. Element
- B. Grommet

- Apply a little grease around the element fence hole against the grommet side, and put the spring on the element fence hole.
- Install the element with the spring so that the spring fits into the proper position.

- Apply a little engine oil to the grommet, and install the oil filter cover and tighten its bolts.

### NOTE

- *Install the oil filter cover while aligning the holes of the cover.*

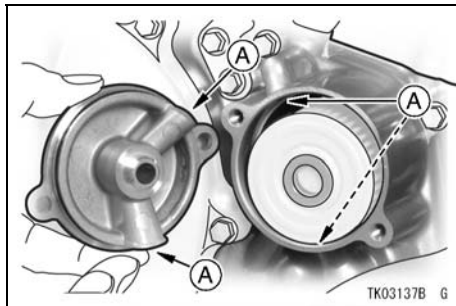

#### A. Holes

- After the oil has completely drained out, install the engine oil drain plug

with its gasket. Proper torque for it is shown in the table.

### NOTE

- *Replace the any gasket with a new one.*
- Fill the engine up to the upper level line with a good quality motor oil specified in the table.
- Start the engine.
- Check the oil level and for oil leakage.

#### Tightening Torque

Engine Oil Drain Plug:

15 N·m (1.5 kgf·m, 11 ft·lb)

### NOTE

- *If a torque wrench is not available, this item should be serviced by a Kawasaki dealer.*

## 82 MAINTENANCE AND ADJUSTMENT

### Recommended Engine Oil

Type: API SG, SH, SJ, SL or SM  
with JASO MA, MA1 or MA2

Viscosity: SAE 10W-40

### NOTE

- Do not add any chemical additive to the oil. Oils fulfilling the above requirements are fully formulated and provide adequate lubrication for both the engine and the clutch.

### Engine Oil Capacity

Capacity: 1.0 L (1.1 US qt)  
[when filter is not removed]  
1.1 L (1.2 US qt)  
[when filter is removed]  
1.3 L (1.4 US qt)  
[when engine is completely dry]

Although 10W-40 engine oil is the recommended oil for most conditions, the oil viscosity may need to be changed to accommodate atmospheric conditions in your riding area.

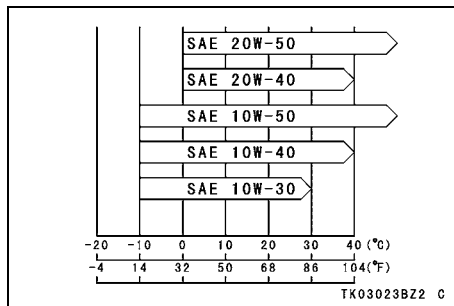

## Cooling System

### Radiator and Cooling Fan -

Check the radiator fins for obstruction by insects or mud. Clean off any obstructions with a stream of low-pressure water.

 **WARNING**

**Keep your hands and clothing away from the fan blades at all times.**

## **NOTICE**

**Using high-pressure water, as from a car wash facility, could damage the radiator fins and impair the radiator's effectiveness. Do not obstruct or deflect airflow through the radiator by installing unauthorized accessories in front of the radiator or behind the cooling fan. Interference with the radiator airflow can lead to overheating and consequent engine damage.**

### Radiator Hoses -

Check the radiator hoses for leakage, cracks or deterioration, and connections for leakage, or looseness each day before riding the motorcycle, and in accordance with the Periodic Maintenance Chart.

## 84 MAINTENANCE AND ADJUSTMENT

### Coolant -

Coolant absorbs excessive heat from the engine and transfers it to the air at the radiator. If the coolant level becomes low, the engine overheats and may suffer severe damage. Check the coolant level each day before riding the motorcycle, and in accordance with the periodic maintenance chart, and replenish coolant if the level is low. Change the coolant in accordance with the Periodic Maintenance Chart.

#### *Information for Coolant*

To protect the cooling system (consisting of the aluminum engine and radiator) from rust and corrosion, the use of corrosion and rust inhibitor chemicals in the coolant is essential. If coolant containing corrosion and rust inhibitor chemicals is not used, over a

period of time, the cooling system accumulates rust and scale in the water jacket and radiator. This will clog up the coolant passages, and considerably reduce the efficiency of the cooling system.

### **WARNING**

**Coolant containing corrosion inhibitors for aluminum engines and radiators include harmful chemicals for human body. Drinking coolant can result in serious injury or death. Use coolant in accordance with the instructions of the manufacturer.**

Soft or distilled water must be used with the antifreeze (see below for antifreeze) in the cooling system.

**NOTICE**

**If hard water is used in the system, it causes scale accumulation in the water passages, and considerably reduces the efficiency of the cooling system.**

If the lowest ambient temperature encountered falls below the freezing point of water, use permanent antifreeze in the coolant to protect the cooling system against engine and radiator freeze-up, as well as from rust and corrosion.

Use a permanent type of antifreeze (soft water and ethylene glycol plus corrosion and rust inhibitor chemicals for aluminum engines and radiators) in the cooling system. On the mixture ratio of coolant, choose the suitable one referring to the relation between freezing point and strength directed on the container.

**NOTICE**

**Permanent types of antifreeze on the market have anti-corrosion and anti-rust properties. When it is diluted excessively, it loses its anti-corrosion property. Dilute a permanent type of antifreeze in accordance with the instructions of the manufacturer.**

**NOTE**

- *A permanent type of antifreeze is installed in the cooling system when shipped. It is colored green and contains ethylene glycol. It is mixed at 50% and has the freezing point of  $-35^{\circ}\text{C}$  ( $-31^{\circ}\text{F}$ ).*

*Coolant Level Inspection*

- Check the coolant level with the motorcycle held level. The coolant level

## 86 MAINTENANCE AND ADJUSTMENT

should be between the F(FULL) and L(LOW) level lines.

### NOTE

- Check the level when the engine is cold (room or atmospheric temperature.)

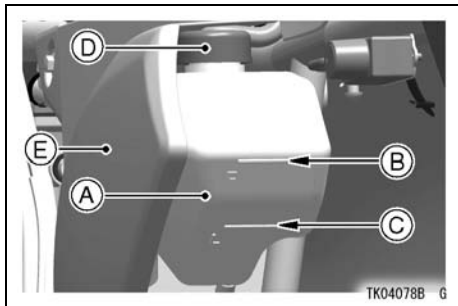

- A. Reserve Tank
- B. F(FULL) Level Line
- C. L( LOW) Level Line
- D. Tank Cap
- E. Left Side Cover

- If the amount of coolant is insufficient, after removing the left side cover, unscrew the cap from the reserve tank and add coolant through the filler opening to the F(FULL) level line.
- Install the cap.

### NOTE

- In an emergency you can add water alone to the coolant reserve tank, however it must be returned to the correct mixture ratio by the addition of antifreeze concentrate as soon as possible.



## ***NOTICE***

**If coolant must be added often, or the reserve tank completely runs dry, there is probably leakage in the system. Have the cooling system inspected by your authorized Kawasaki dealer.**

### *Coolant Change*

Have the coolant changed by an authorized Kawasaki dealer.

## **Spark Plugs**

The standard spark plug is shown in the table. The spark plug should be taken out in accordance with the Periodic Maintenance Chart for cleaning, inspection, and resetting of the plug gap.

### *Maintenance*

If the plug is oily or has carbon built up on it, have it cleaned, preferably in a sand-blasting device, and then clean off any abrasive particles. The plug may also be cleaned using a high flash-point solvent and a wire brush or other suitable tool. Measure the gap with a wire-type thickness gauge, and adjust the gap if incorrect by bending the outer electrode. If the spark plug electrodes are corroded or damaged, or if the insulator is cracked, replace the plug. Use the standard plug.

## 88 MAINTENANCE AND ADJUSTMENT

### Spark Plug

Standard Plug	NGK CR8E
Plug Gap	0.7 ~ 0.8 mm (0.028 ~ 0.031 in.)
Tightening Torque	13 N·m (1.3 kgf·m, 115 in·lb)

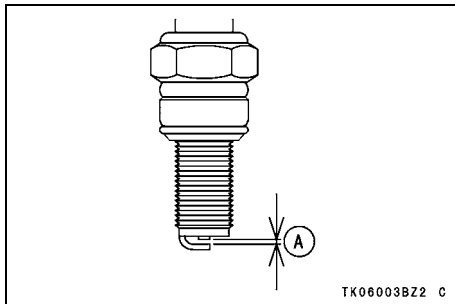

A. Plug Gap

### NOTE

- If a torque wrench is not available, this item should be serviced by a Kawasaki dealer.

### NOTICE

For cold weather and/or low speed riding, a hotter spark plug shown in the table may be used for quicker warm-ups and more efficient engine operation. However, for normal temperatures and/or high speed use, the standard spark plug must be used to prevent engine damage.

### Hotter Spark Plug

NGK CR7E

## Valve Clearance

Valve and valve seat wear decreases valve clearance, upsetting valve timing.

### **NOTICE**

**If valve clearance is left unadjusted, wear will eventually cause the valves to remain partly open, which lowers performance, burns the valves and valve seats, and may cause serious engine damage.**

Valve clearance for each valve should be checked and adjusted in accordance with the Periodic Maintenance Chart.

Inspection and adjustment should be done by an authorized Kawasaki dealer.

## Kawasaki Clean Air System

The Kawasaki Clean Air System (KCA) is a secondary air suction system that helps the exhaust gases to burn more completely. When the spent fuel charge is released into the exhaust system, it is still hot enough to burn. The KCA System allows extra air into the exhaust system so that the spent fuel charge can continue to burn. This continued burning action tends to burn up a great deal of the normally unburned gases, as well as changing a significant portion of the carbon monoxide into carbon dioxide.

### **Air Suction Valves -**

The air suction valve is essentially a check valve which allows fresh air to flow only from the air cleaner into the exhaust port. Any air that has passed the air suction valve is prevented from returning. Inspect the air suction valves

## 90 MAINTENANCE AND ADJUSTMENT

in accordance with the Periodic Maintenance Chart. Also, inspect the air suction valves whenever stable idling cannot be obtained, engine power is greatly reduced, or there are abnormal engine noises.

Air suction valve removal and inspection should be carried out by an authorized Kawasaki dealer.

### **Air Cleaner**

A clogged air cleaner restricts the engine's air intake, increasing fuel consumption, reducing engine power, and causing spark plug fouling.

The air cleaner element must be cleaned in accordance with the Periodic Maintenance Chart. In dusty areas, the element should be cleaned more frequently than the recommended interval. After riding through rain or on muddy roads, the element should be cleaned immediately. The element should be replaced if it is damaged.

*Element Removal*

- Remove the seat.
- Unscrew the air cleaner intake cap bolts and remove the air cleaner intake cap.

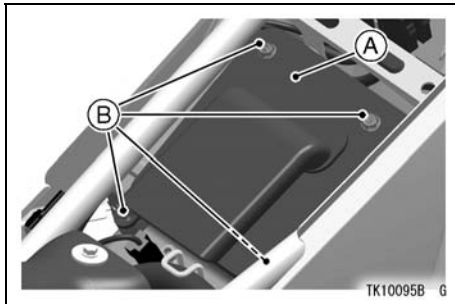

A. Air Cleaner Intake Cap  
B. Bolts

- Remove the wing bolt, and take out the element.

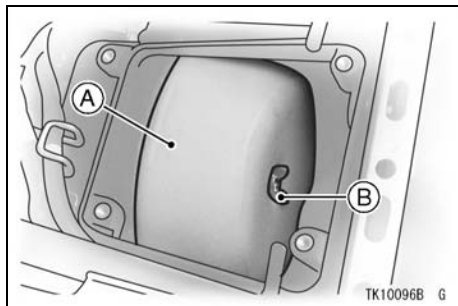

A. Element  
B. Wing Bolt

## 92 MAINTENANCE AND ADJUSTMENT

- Remove the element from the frame.

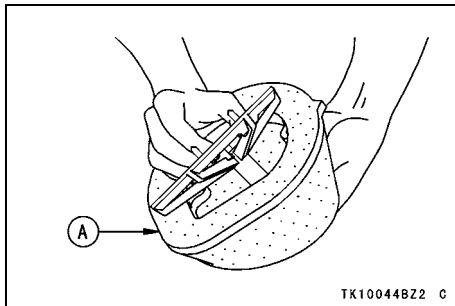

### A. Element

- Put a clean, lint-free towel over the air cleaner housing to keep dirt or other foreign material from entering.
- Inspect the element material for damage. If any part of the element is

damaged, the element must be replaced.

### **⚠ WARNING**

**If dirt or dust is allowed to pass through into the fuel injection system, the throttle may stick or become inoperable resulting in a hazardous operating condition.**

### **NOTICE**

**If dirt gets through into the engine, excessive engine wear and possibly engine damage will occur.**

**NOTE**

- *Element installation is performed in the reverse order of removal.*
- *When installing the element, coat the lip of the element with a thick layer of all purpose grease to assure a complete seal against the air cleaner element base. Also, coat the base where the lip of the element fits.*

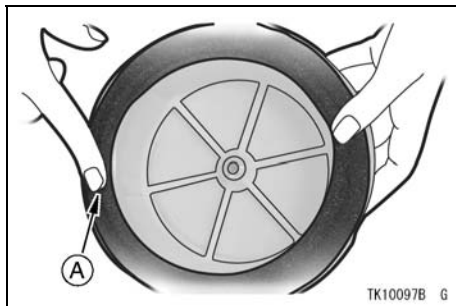
**A. Grease***Element Cleaning*

- Clean the element in a bath of a high flash-point solvent.

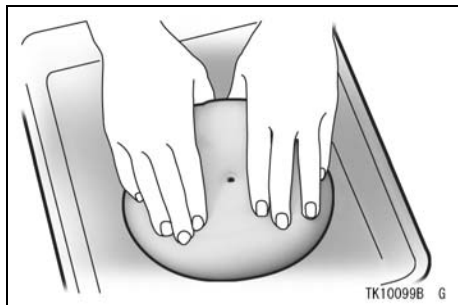

## 94 MAINTENANCE AND ADJUSTMENT

- Dry the element with compressed air or by squeeze it.
- After cleaning, saturate the element with engine oil or high-quality foam-air-filter oil, squeeze out the excess oil, then wrap it in a clean rag and squeeze it as dry as possible. Be careful not to tear the element.

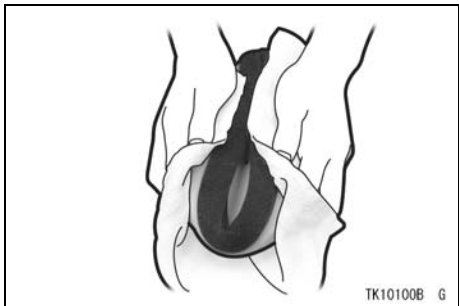

### **⚠ WARNING**

**Gasoline and low flash-point solvents are extremely flammable and may explode, causing severe burns. Do not use gasoline or a low flash-point solvent to clean the element. Clean the element in a well-ventilated area. Be sure there are no sparks or flame in the work area, including any appliance with a pilot light.**

#### *Oil Draining*

- If there is any oil in the reservoir, remove the plug from the lower end of the drain hose and drain the oil.



**⚠ WARNING**

**Oil on tires will make them slippery and can cause an accident any injury. Be sure to install the plug in the drain hose after draining.**

- Inspect the transparent reservoir located under the rear shock absorber to see if any oil has run down from the air cleaner housing.

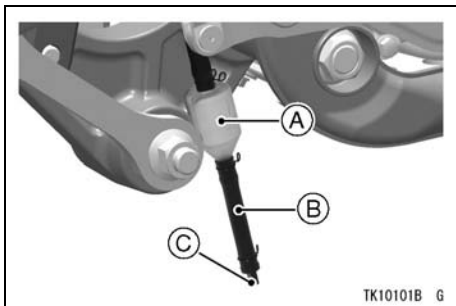

- A. Reservoir
- B. Drain Hose
- C. Plug

### Throttle Grip

The throttle grip controls the throttle valves. If the throttle grip has excessive play due to either cable stretch or maladjustment, it will cause a delay in throttle response, especially at low engine speed. Also, the throttle valves may not open fully at full throttle. On the other hand, if the throttle grip has no play, the throttle will be hard to control, and the idle speed will be erratic. Check the throttle grip play in accordance with the Periodic Maintenance Chart, and adjust the play if necessary.

#### *Inspection*

- Check that there is 2 ~ 3 mm (0.08 ~ 0.12 in.) throttle grip play when lightly turning the throttle grip back and forth.
- If there is improper play, adjust it.

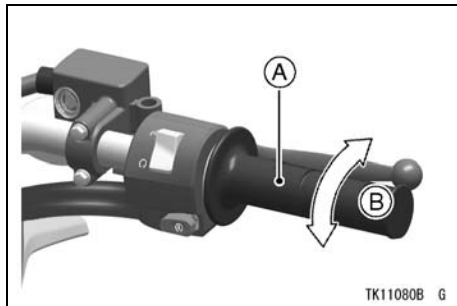

#### **A. Throttle Grip**

**B. 2 ~ 3 mm (0.08 ~ 0.12 in.)**

#### *Adjustment*

- Loosen the locknuts at the upper end of the throttle cable and at the middle

of the throttle cable. Turn both adjuster in completely so as to give the throttle grip plenty of play.

- Turn out the decelerator cable adjuster until there is no play when the throttle grip is completely closed. Tighten the locknut.

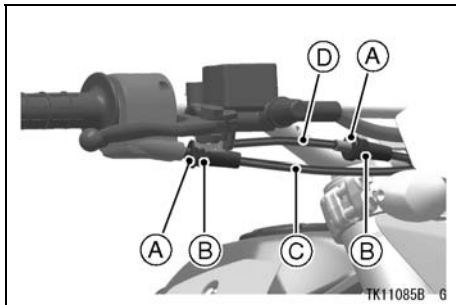

- A. Locknuts
- B. Adjusters
- C. Accelerator Cable
- D. Decelerator Cable

- Turn out the accelerator cable adjuster until a play of 2 ~ 3 mm (0.08 ~ 0.12 in.) is obtained at the throttle grip. Tighten the locknut.

## **⚠ WARNING**

**Operation with improperly adjusted, incorrectly routed, or damaged cables could result in an unsafe riding condition. Be sure the control cables are adjusted and routed correctly, and are free from damage.**

## 98 MAINTENANCE AND ADJUSTMENT

### Idle Speed

The idle speed adjustment should be performed in accordance with the Periodic Maintenance Chart or whenever idle speed is disturbed.

### *Adjustment*

- Start the engine, and warm it up thoroughly.
- Adjust the idle speed to 1 250 ~ 1 350 r/min (rpm) by turning the idle adjusting screw.

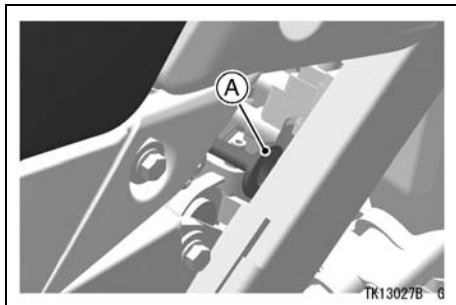

**A. Idle Adjusting Screw**

- Open and close the throttle a few times to make sure that the idle speed does not change. Readjust if necessary.

- With the engine idling, turn the handlebar to each side. If handlebar movement changes the idle speed, the throttle cables may be improperly adjusted or incorrectly routed, or they may be damaged. Be sure to correct any of these conditions before riding.

**⚠ WARNING**

**Operation with damaged cables could result in an unsafe riding condition. Replace damaged control cables before operation.**

## Clutch

Due to friction plate wear and clutch cable stretch over a long period of use, the clutch operation should be checked each day before riding the motorcycle, and in accordance with the Periodic Maintenance Chart.

**⚠ WARNING**

**The engine and exhaust system get extremely hot during normal operation and can cause serious burns. Never touch a hot engine or an exhaust pipe during clutch adjustment.**

### *Inspection*

- Check that the clutch lever operates properly and that the inner cable slides smoothly. If there is any irregularity, have the clutch cable checked by an authorized Kawasaki dealer.

## 100 MAINTENANCE AND ADJUSTMENT

- Slide the dust cover.
- Check the clutch lever play as shown in the figure.

### Clutch Lever Play

2 ~ 3 mm (0.08 ~ 0.12 in.)

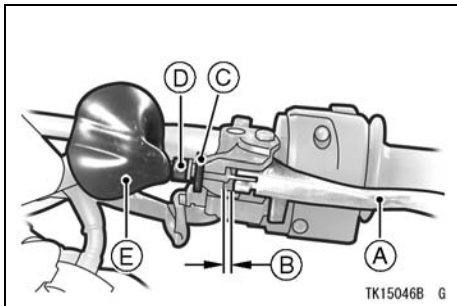

- A. Clutch Lever
- B. Clutch Lever Play
- C. Locknut
- D. Adjuster
- E. Dust Cover

If the play is incorrect, adjust the lever play as follows.

### Adjustment

- Slide the dust cover at the clutch lever out of place.
- Loosen the locknut at the clutch lever.
- Turn the adjuster so that the clutch lever will have the proper play.

## **⚠ WARNING**

Too much cable play can prevent clutch disengagement and cause an accident resulting in serious injury or death. When adjusting the clutch or replacing the cable, be sure the upper end of the clutch outer cable is fully seated in its fitting, or it could slip into place later, creating enough cable play to prevent clutch disengagement.

- Tighten the locknut.
- If it cannot be done at the clutch lever, use the adjusting nut at the middle of the cable.
- Loosen the locknut at the clutch lever.
- Turn the adjuster in all the way, then tighten the locknut.

- Loosen the locknut at the middle of the cable, and turn the adjusting nut so that the clutch lever has 2 ~ 3 mm (0.08 ~ 0.12 in.) of play.

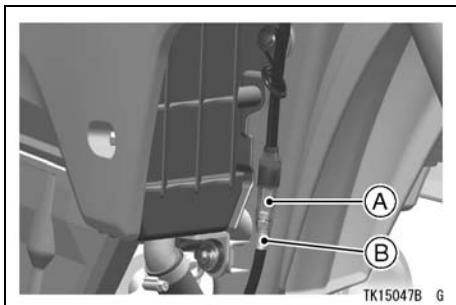

- A. Adjusting Nut
- B. Locknut

- Tighten the locknut.
- Slide the dust cover back into place.

## NOTE

- *After the adjustment is made, start the engine and check that the clutch does not slip and that it releases properly.*

### **DANGER**

**Exhaust gas contains carbon monoxide, a colorless, odorless poisonous gas.**

**Inhaling carbon monoxide can cause serious brain injury or death.**

**Do not run the engine in enclosed areas. Operate only in a well-ventilated area.**

## Drive Chain

The drive chain slack and lubrication must be checked each day before riding the motorcycle, and in accordance with the Periodic Maintenance Chart for safety and to prevent excessive wear. If the chain becomes badly worn or maladjusted - either too loose or too tight - the chain could jump off the sprockets or break.

### **WARNING**

**A chain that breaks or jumps off the sprockets could snag on the engine sprocket or lock the rear wheel, severely damaging the motorcycle and causing it to go out of control. Inspect the chain for damage and proper adjustment before each ride.**



### Chain Slack Inspection

- Set the motorcycle up on its side stand.
- Rotate the rear wheel to find the position where the chain is tightest and measure the maximum chain slack by pulling up and pushing down the chain midway between the engine sprocket and rear wheel sprocket.

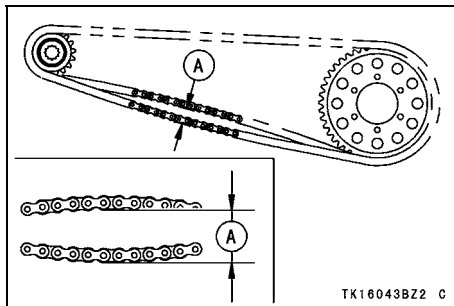

A. Chain Slack

- If the drive chain is too tight or too loose, adjust it so that the chain slack will be within the standard value.

### Drive Chain Slack

Standard	35 ~ 45 mm (1.4 ~ 1.8 in.)
----------	----------------------------

### Chain Slack Adjustment

- Remove the cotter pin, and loosen the axle nut.

## 104 MAINTENANCE AND ADJUSTMENT

- Loosen the left and right chain adjuster locknuts.

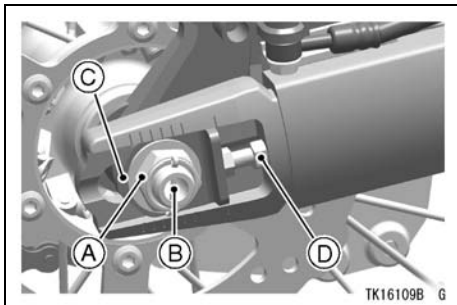

- A. Axle Nut
- B. Cotter Pin
- C. Indicator
- D. Locknut

- Turn in the left and right chain adjusters evenly to obtain the standard chain slack. To keep the chain and wheel properly aligned, the notch on the right wheel alignment indicator should align with the same swingarm mark that the left indicator notch align with.

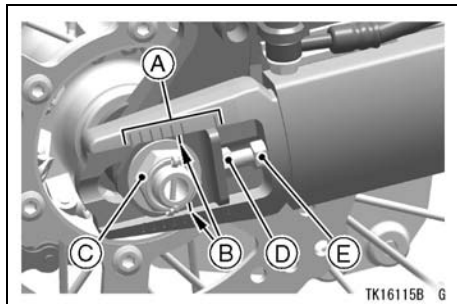

- A. Marks
- B. Notch
- C. Axle Nut
- D. Adjuster
- E. Locknut

**NOTE**

- *Wheel alignment can also be checked using the straightedge or string method.*

 **WARNING**

**Misalignment of the wheel will result in abnormal wear, and may result in an unsafe riding condition. Align the rear wheel using the marks on the swingarm or measuring the distance between the center of the axle and swingarm pivot.**

- Tighten both chain adjuster locknuts.
- Tighten the axle nut to the specified torque.

**Tightening Torque**

Axle Nut:  
110 N·m (11.0 kgf·m, 80 ft·lb)

**NOTE**

- *If a torque wrench is not available, this item should be serviced by a Kawasaki dealer.*
- Rotate the wheel, measure the chain slack again at the tightest position, and readjust if necessary.
- Insert a new cotter pin through the axle, and spread its ends.
- Check the rear brake (see the Brakes section).

 **WARNING**

**A loose axle nut can lead to an accident resulting in serious injury or death. Tighten the axle nut to the proper torque and install a new cotter pin.**

## 106 MAINTENANCE AND ADJUSTMENT

### *Wear Inspection*

- Stretch the chain taut either by using the chain adjusters, or by hanging a 10 kg (20 lb) weight on the chain.

- Measure the length of 20 links on the straight part of the chain from pin center of the 1st pin to pin center of the 21st pin. Since the chain may wear unevenly, take measurements at several places.
- If the length exceeds the service limit, the chain should be replaced.

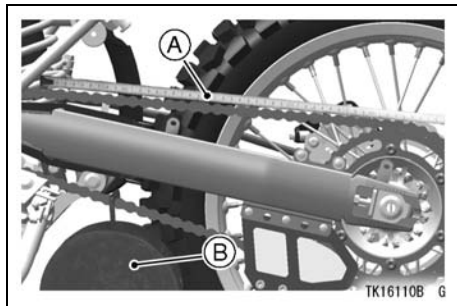

- A. Measure
- B. Weight

**Drive Chain 20-Link Length**

Service Limit: 323 mm (12.7 in.)

**⚠ WARNING**

**For safety, use only the standard chain. It is an endless type and should not be cut for installation; have it installed by an authorized Kawasaki dealer.**

- Rotate the rear wheel to inspect the drive chain for damaged rollers, and loose pins and links.
- Also inspect the sprockets for unevenly or excessively worn teeth, and damaged teeth.

**NOTE**

- *Sprocket wear is exaggerated for illustration. See Service Manual for wear limits.*

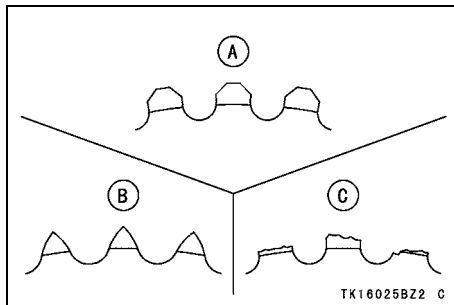

- A. Good Teeth**
- B. Worn Teeth**
- C. Damaged Teeth**

- If there is any irregularity, have the drive chain and/or the sprockets replaced by an authorized Kawasaki dealer.

## 108 MAINTENANCE AND ADJUSTMENT

### *Lubrication*

Lubrication is also necessary after riding through rain or on wet roads, or any time that the chain appears dry. A heavy oil such as SAE 90 is preferred to a lighter oil because it will stay on the chain longer and provide better lubrication.

- Apply oil to the sides of the rollers so that it will penetrate to the rollers and bushings. Apply oil to the O-rings so that the O-rings will be coated with oil. Wipe off any excess oil.

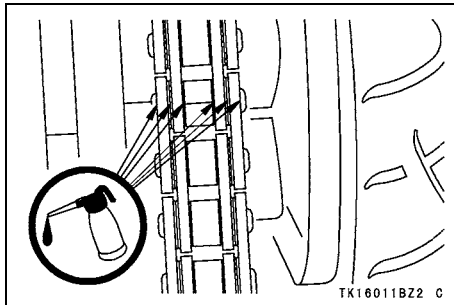

- If the chain is especially dirty, clean it using diesel oil or kerosine and then apply oil as described above.

## Brakes

### *Brake Wear Inspection*

Inspect the brakes for wear. For each front and rear disc brake caliper, if the thickness of either pad is less than 1 mm (0.04 in.), replace both pads in the caliper as a set. Pad replacement should be done by an authorized Kawasaki dealer.

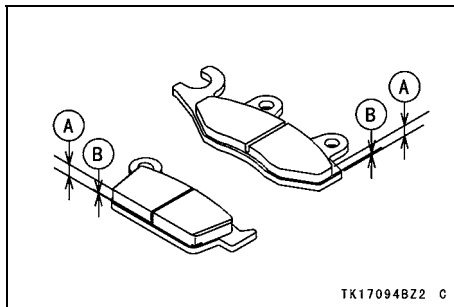

- A. Lining Thickness
- B. 1 mm (0.04 in.)

### **Disc Brake Fluid -**

In accordance with the Periodic Maintenance Chart, inspect the brake fluid level in both the front and rear brake fluid reservoir and change the brake fluid. The brake fluid should also be changed if it becomes contaminated with dirt or water.

### *Fluid Requirement*

Use heavy-duty brake fluid only from a container marked DOT3 or DOT4.

## NOTICE

**Do not spill brake fluid onto any painted surface.**

**Do not use fluid from a container that has been left open or that has been unsealed for a long time.**

**Check for fluid leakage around the fittings.**

**Check for brake hose damage.**

### *Fluid Level Inspection*

- The brake fluid level in the front brake fluid reservoir must be kept above the line (lower level line) next to the gauge and that in the rear brake fluid reservoir must be kept between the upper and lower level lines (reservoirs held horizontal).

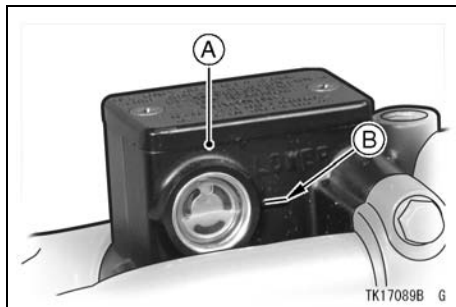

**A. Front Brake Fluid Reservoir**  
**B. Lower Level Line**



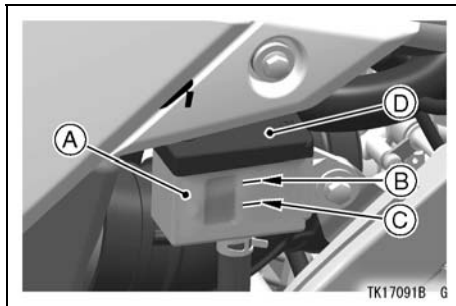

- A. Rear Brake Fluid Reservoir
- B. Upper Level Line
- C. Lower Level Line
- D. Cap

- If the fluid level in either reservoir is lower than the lower level line, check for fluid leaks in the brake lines, and fill the reservoir to the upper level line. Inside the front reservoir is a stepped line showing the upper level line.

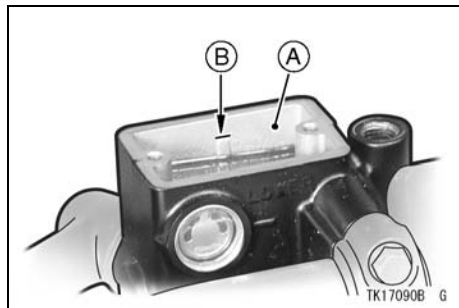

- A. Front Brake Fluid Reservoir
- B. Upper Level Line

 **WARNING**

Mixing brands and types of brake fluid can reduce the brake system's effectiveness and cause an accident resulting in injury or death. Do not mix two brands of brake fluid. Change the brake fluid in the brake line completely if the brake fluid must be refilled but the type and brand of the brake fluid that is already in the reservoir are unidentified.

*Fluid Change*

Have the brake fluid changed by an authorized Kawasaki dealer.

**Front and Rear Brakes -**

Disc and disc pad wear is automatically compensated for and has no effect on the brake lever or pedal action.

So there are no parts that require adjustment on the front and rear brakes.

 **WARNING**

Air in the brake lines diminish braking performance and can cause an accident resulting in injury or death. If the brake lever or pedal feels mushy when it is applied, there might be air in the brake lines or the brake may be defective. Have the brake checked immediately by an authorized Kawasaki dealer.

## Brake Light Switches

When either the front or rear brake is applied, the brake light goes on. The front brake light switch requires no adjustment, but the rear brake light switch should be adjusted in accordance with the Periodic Maintenance Chart.

### Inspection

- Turn the ignition key to "ON".
- The brake light should go on when the front brake is applied.
- If it does not, ask your authorized Kawasaki dealer to inspect the front brake light switch.

- Check the operation of the rear brake light switch by depressing the brake pedal. The brake light should go on after about 10 mm (0.4 in.) of pedal travel.

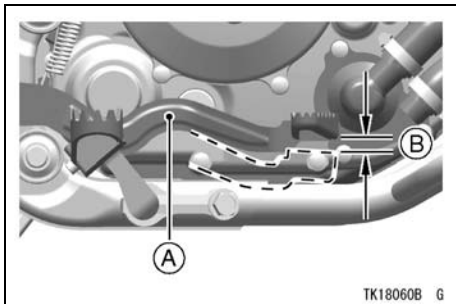

- A. Brake Pedal**  
**B. 10 mm (0.4 in.)**

- If it does not, adjust the rear brake light switch.

## 114 MAINTENANCE AND ADJUSTMENT

### *Adjustment*

- To adjust the rear brake light switch, move the switch up or down by turning the adjusting nut.

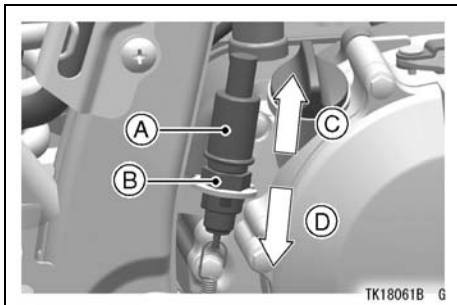

- A. Rear Brake Light Switch
- B. Adjusting Nut
- C. Lights sooner
- D. Lights later

## ***NOTICE***

**To avoid damaging the electrical connections inside the switch, be sure that the switch body does not turn during adjustment.**

## Front Fork

The front fork operation and oil leakage should be checked in accordance with the Periodic Maintenance Chart.

### *Front Fork Inspection*

- Holding the brake lever, pump the front fork up and down by several times for inspection of smooth stroke.
- Visually inspect the front fork for oil leakage, scoring or scratches on the outer surface of the inner tube.

- If any doubt about the front fork, it should be done by an authorized Kawasaki dealer.

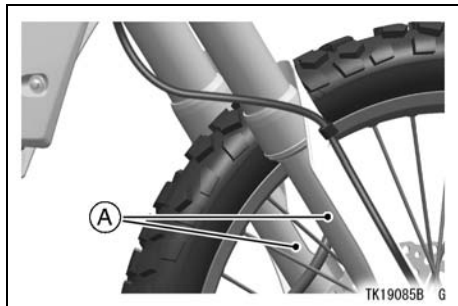

**A. Inner Tube**

### *Air Pressure*

The standard air pressure in the front fork legs is atmospheric pressure. The air pressure in the fork legs increases as the fork heats up, so the fork action will get stiffer as the vehicle operation progresses.

## 116 MAINTENANCE AND ADJUSTMENT

### *Compression Damping Adjustment*

- Using the jack under the frame, stabilize the motorcycle.
- Place a stand or block under the engine so that the front wheel is raised off the ground.
- Clean the bottom of the outer tubes.

- To adjust compression damping, turn the adjuster on the front fork cylinder valve with the blade of a screwdriver until you feel a click. Adjust the compression damping to suit your preference under special condition.

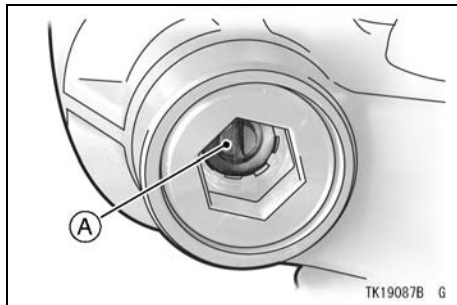

A. Adjuster

### **NOTICE**

**The left and right fork legs must have the same shock damping.**

The standard setting position of the compression damping force adjuster, for an average build rider of 68 kg (150 lb) with no passenger and no accessories is as follows.

Compression Damping Force Adjuster	12 clicks*
------------------------------------	------------

\* out from the fully seated position

## Rear Shock Absorber

The rear shock absorber operation and oil leakage should be checked in accordance with the Periodic Maintenance Chart.

## 118 MAINTENANCE AND ADJUSTMENT

### *Rear Shock Absorber Inspection*

- Press down on the seat several times to check if the rear shock absorber stroke is smooth.
- Visually inspect the rear shock absorber for oil leakage.
- If any doubt about the rear shock absorber, it should be done by an authorized Kawasaki dealer.

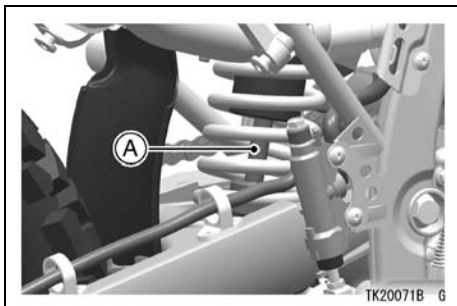

**A. Rear Shock Absorber**

### *Rebound Damping Adjustment*

To adjust shock rebound damping, turn the rebound damping adjuster on the rear shock absorber lower end with the blade of a screwdriver until you feel a click.

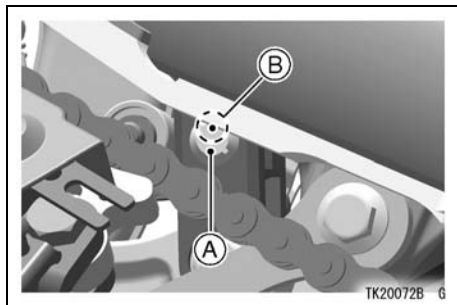

**A. Rebound Damping Adjuster**

**B. Mark**



*Compression Damping Adjustment*

To adjust compression damping, turn the compression damping adjuster on the gas reservoir with the blade of a screwdriver until you feel a click.

Rebound Damping Force Adjuster	12 turns out*
Compression Damping Force Adjuster	16 turns out*

\* out from the fully seated position

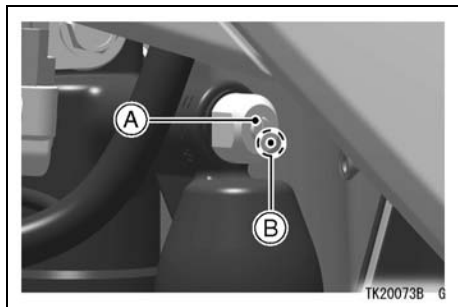

**A. Compression Damping Adjuster**

**B. Mark**

*Spring Preload Adjustment*

The rear shock absorber can be adjusted by changing the spring preload for various riding and loading conditions. If the spring action feels too soft or too stiff, have it adjusted by an authorized Kawasaki dealer.

### Wheels

#### Tires -

##### *Payload and Tire Pressure*

Failure to maintain proper inflation pressures or observe payload limits for your tires may adversely affect handling and performance of your motorcycle and can result in loss of control. The maximum recommended load in addition to vehicle weight is 181 kg (399 lb), including rider, passenger, baggage, and accessories.

- Remove the air valve cap.
- Check the tire pressure often, using an accurate gauge.
- Make sure to install the air valve cap securely installed.

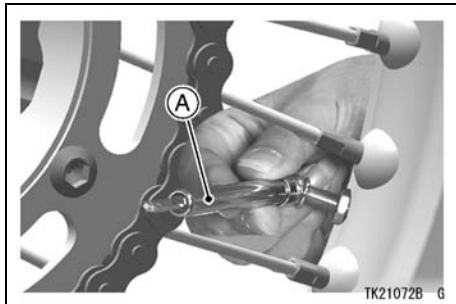

**A. Tire Pressure Gauge**

**NOTE**

- *Measure the tire pressure when the tires are cold (that is, when the motorcycle has not been ridden more than a mile during the past 3 hours).*
- *Tire pressure is affected by changes in ambient temperature and altitude, and so the tire pressure should be checked and adjusted when your riding involves wide variations in temperature or altitude.*

**Tire Air Pressure (when cold)**

Front	---	150 kPa (1.50 kgf/cm <sup>2</sup> , 22 psi)
Rear	Up to 97.5 kg (215 lb) Load	150 kPa (1.50 kgf/cm <sup>2</sup> , 22 psi)
	97.5 ~ 181 kg (215 ~ 399 lb) Load	175 kPa (1.75 kgf/cm <sup>2</sup> , 25 psi)

*Tire Wear, Damage*

As the tire tread wears down, the tire becomes more susceptible to puncture and failure. An accepted estimate is that 90% of all tire failures occur during the last 10% of tread life (90 % worn). So it is false economy and unsafe to use the tires until they are bald.

## 122 MAINTENANCE AND ADJUSTMENT

- In accordance with the Periodic Maintenance Chart, measure the depth of the tread with a depth gauge, and replace any tire that has worn down to the minimum allowable tread depth.

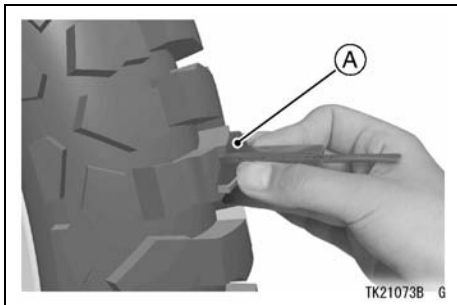

A. Tire Depth Gauge

### Minimum Tread Depth

Front	2 mm (0.08 in.)
Rear	2 mm (0.08 in.)

- Visually inspect the tire for cracks and cuts, replacing the tire in case of bad damage. Swelling or high spots indicate internal damage, requiring tire replacement.
- Remove any imbedded stones or other foreign particles from the tread.

### NOTE

- *Have the wheel balance inspected whenever a new tire is installed.*

**⚠ WARNING**

Tires that have been punctured and repaired do not have the same capabilities as undamaged tires and can suddenly fail, causing an accident resulting in serious injury or death. Replace damaged tires as soon as possible. To ensure safe handling and stability, use only the recommended standard tires for replacement, inflated to the standard pressure. If it is necessary to ride on a repaired tire, do not exceed 100 km/h (60 mph) until the tire is replaced.

**NOTE**

- *Most countries may have their own regulations requiring a minimum tire tread depth; be sure to follow them.*

- *When operating on public roadways, keep maximum speed under traffic law limits.*

**Standard Tire**

Front	Size: 3.00-21 51P DUNLOP D605FG
Rear	Size: 4.60-18 63P DUNLOP D605G

**⚠ WARNING**

**New tires are slippery and may cause loss of control and injury. A break-in period of 160 km (100 miles) is necessary to establish normal tire traction. During break-in, avoid sudden and maximum braking and acceleration, and hard cornering.**

### Battery

The battery installed in this motorcycle is a sealed type, so it is not necessary to check the battery electrolyte level or add distilled water.

The sealing strip should not be pulled off once the specified electrolyte has been installed in the battery for initial service.

However, in order to maximize battery life and ensure that it will provide the power needed to start the motorcycle you must properly maintain the battery's charge. When used regularly, the charging system in the motorcycle helps keep the battery fully charged. If your motorcycle is only used occasionally or for short periods of time, the battery is more likely to discharge.

Due to their internal composition, batteries continually self discharge. The discharge rate depends on the type of battery and ambient temperature. As temperatures rise, so does the discharge rate. Every 15°C (27°F) doubles the rate.

Electrical accessories, such as digital clocks and computer memory, also draw current from the battery even when the key is switched off. Combine such "key-off" draws with hot temperature, and a battery can go from fully charged to completely discharged in a matter of days.

Self-discharge		
Temperature	Approx. Number of Days From 100% Charged to 100% discharged	
	Lead -Antimony	Lead -Calcium
	Battery	Battery
40°C (104°F)	100 Days	300 Days
25°C (77°F)	200 Days	600 Days
0°C (32°F)	550 Days	950 Days

Current Drain		
Discharging Ampere	Days from 100% charged to 50% Discharged	Days from 100% charged to 100% Discharged
7 mA	60 Days	119 Days
10 mA	42 Days	83 Days
15 mA	28 Days	56 Days
20 mA	21 Days	42 Days
30 mA	14 Days	28 Days

In extremely cold weather the fluid in an inadequately charged battery can easily freeze, which can crack the case and buckle the plates. A fully charged battery can withstand sub-freezing temperatures with no damage.

### **Battery Sulfation**

A common cause of battery failure is sulfation.

Sulfation occurs when the battery is left in a discharged condition for an extended time. Sulfate is a normal by product of the chemical reactions within a battery. But when continuous discharge allows the sulfate to crystallize in the cells, the battery plates become permanently damaged and will not hold a charge. Battery failure due to sulfation is not warrantable.

### **Battery Maintenance**

It is the owner's responsibility to keep the battery fully charged. Failure to do so can lead to battery failure and leave you stranded.

If you are riding your vehicle infrequently, inspect the battery voltage weekly using a voltmeter. If it drops

below 12.6 volts, the battery should be charged using an appropriate charger (check with your Kawasaki dealer). If you will not be using the motorcycle for longer than two weeks, the battery should be charged using an appropriate charger. Do not use an automotive-type quick charger that may overcharge the battery and damage it.

### **Kawasaki-recommended chargers are:**

Battery Mate 150-9

OptiMate PRO 4-S/PRO S/PRO 2

Yuasa MB-2040/2060

Christie C10122S

If the above chargers are not available, use equivalent one.

For more details, ask your Kawasaki dealer.



## Battery Charging

- Remove the battery from the motorcycle (see Battery Removal).
- Attach the leads from the charger and charge the battery at a rate (amperage × hours) that is indicated on the battery. If it is not possible to read the rate, charge the battery at an amperage that is about 1/10th of the battery capacity.
- The charger will keep the battery fully charged until you are ready to re-install the battery in the motorcycle (see Battery Installation).

## NOTICE

**Never remove the sealing strip, or the battery can be damaged. Do not install a conventional battery in this motorcycle, or the electrical system cannot work properly.**

## NOTE

- *If you charge the sealed battery, never fail to observe the instructions shown in the label on the battery.*

### *Battery Removal*

- Remove the left side cover.
- Disconnect the leads from the battery, first from the (–) terminal and then the (+) terminal.

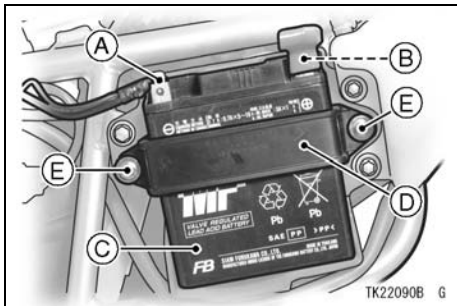

- A. (-) Terminal
- B. (+) Terminal
- C. Battery
- D. Holder
- E. Bolt

- Remove the battery holder, and take the battery out of the battery case.
- Clean the battery using a solution of baking soda and water. Be sure that the wire connections are clean.

### *Battery Installation*

- Put the battery in the battery case.
- Connect the capped lead to the (+) terminal, and then connect the black lead to the (-) terminal.
- Put a light coat of grease on the terminals to prevent corrosion.
- Cover the (+) terminal with its protective cap.
- Reinstall the parts removed.

## Headlight Beam

### *Horizontal Adjustment*

The headlight beam is adjustable horizontally. If not properly adjusted horizontally, the beam will point to one side rather than straight ahead.

- Turn the horizontal adjuster on the headlight rim in or out until the beam points straight ahead.

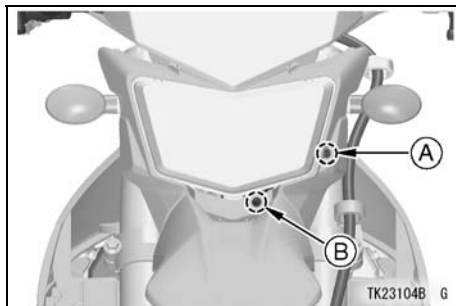

- A. Horizontal Adjuster
- B. Vertical Adjuster

### *Vertical Adjustment*

The headlight beam is adjustable vertically. If adjusted too low, neither low nor high beam will illuminate the road far enough ahead. If adjusted too high, the high beam will fail to illuminate the road close ahead, and the low beam will blind oncoming drivers.

- Turn the vertical adjuster on the headlight rim in or out to adjust the headlight vertically.

## 130 MAINTENANCE AND ADJUSTMENT

### NOTE

- *On high beam, the brightest point should be slightly below horizontal with the motorcycle on its wheels and the rider seated. Adjust the headlight to the proper angle according to local regulations.*

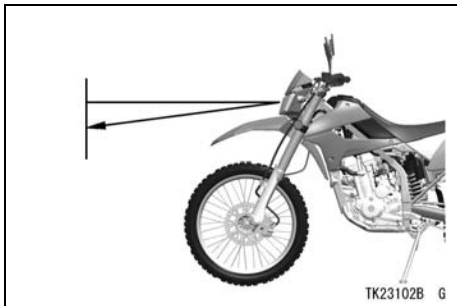

### NOTICE

**When handling the quartz-halogen bulbs, never touch the glass portion with bare hands. Always use a clean cloth. Oil contamination from hands or dirty rags can reduce bulb life or cause the bulb to explode.**

## Fuses

The main fuse is mounted on the starter relay located under the seat. The fuse case is located under the seat. If a fuse fails during operation, inspect the electrical system to determine the cause, and then replace it with a new fuse of proper amperage.

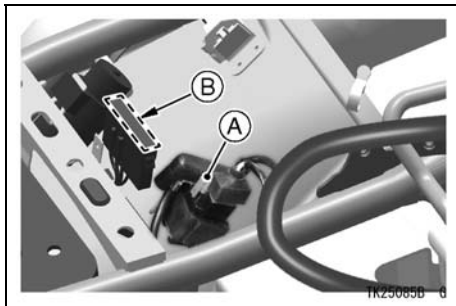

A. Main Fuse (20 A)  
B. Fuse Case

## WARNING

**Substituting fuses can cause wiring to overheat, catch fire and/or fail. Do not use any substitute for the standard fuse. Replace the blown fuse with a new one of the correct capacity, as specified on the fuse box and main fuse.**

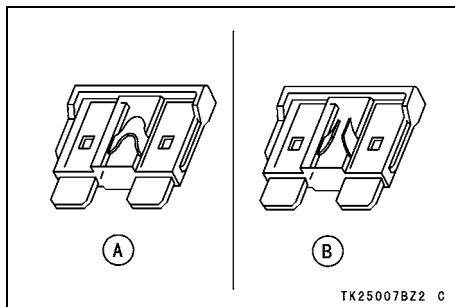

A. Normal  
B. Failed

### Cleaning Your Motorcycle

#### *General Precautions*

Frequent and proper care of your Kawasaki motorcycle will enhance its appearance, optimize overall performance, and extend its useful life. Covering your motorcycle with a high quality, breathable motorcycle cover will help protect its finish from harmful UV rays, pollutants, and reduce the amount of dust reaching its surfaces.

- Be sure the engine and exhaust are cool before washing.
- Avoid applying degreaser to seals, brake pads, and tires.
- Always use non-abrasive wax and cleaner/polisher.
- Avoid all harsh chemicals, solvents, detergents, and household cleaning products such as ammonia-based window cleaners.

- Gasoline, brake fluid, and coolant will damage the finish of painted and plastic surfaces: wash them off immediately.
- Avoid wire brushes, steel wool, and all other abrasive pads or brushes.
- Use care when washing the windshield, headlight cover, and other plastic parts as they can easily be scratched.
- Avoid using pressure washers; water can penetrate seals and electrical components and damage your motorcycle.
- Avoid spraying water in delicate areas such as in air intakes, fuel system, brake components, electrical components, muffler outlets, and fuel tank openings.

### *Washing Your Motorcycle*

- Rinse your bike with cold water from a garden hose to remove any loose dirt.
  - Mix a mild neutral detergent (designed for motorcycles or automobiles) and water in bucket. Use a soft cloth or sponge to wash your motorcycle. If needed, use a mild degreaser to remove any oil or grease build up.
  - After washing, rinse your motorcycle thoroughly with clean water to remove any residue (residue from the detergent can damage parts of your motorcycle).
  - Use a soft cloth to dry your motorcycle. As you dry, inspect your motorcycle for chips and scratches. Do not let the water air dry as this can damage the painted surfaces.
- Start the engine and let it idle for several minutes. The heat from the engine will help dry moist areas.
  - Carefully ride your motorcycle at a slow speed and apply the brakes several times. This helps dry the brakes and restores them to normal operating performance.
  - Lubricate the drive chain to prevent rusting.

### **NOTE**

- *After riding in an area where the roads are salted or near the ocean, immediately wash your motorcycle with cold water. Do not use warm water as it accelerates the chemical reaction of the salt. After drying, apply a corrosion protection spray on all metal and chrome surfaces to prevent corrosion.*

### *Painted Surfaces*

After washing your motorcycle, coat painted surfaces, both metal and plastic, with a commercially available motorcycle/automotive wax. Wax should be applied once every three months or as conditions require. Avoid surfaces with "satin" or "flat" finishes. Always use non-abrasive products and apply them according to the instructions on the container.

### *Plastic Parts*

After washing use a soft cloth to gently dry plastic parts. When dry, treat the headlight lens, and other non-painted plastic parts with an approved plastic cleaner/polisher product.

## **NOTICE**

**Plastic parts may deteriorate and brake if they come in contact with chemical substances or household cleaning products such as gasoline, brake fluid, window cleaners, thread-locking agents, or other harsh chemicals. If a plastic part comes in contact with any harsh chemical substance, wash it off immediately with water and a mild neutral detergent, and then inspect for damage. Avoid using abrasive pads or brushes to clean plastic parts, as they will damage the part's finish.**

### *Chrome and Aluminum*

Chrome and uncoated aluminum parts can be treated with a chrome/aluminum polish. Coated aluminum



should be washed with a mild neutral detergent and finished with a spray polish. Aluminum wheels, both painted and unpainted can be cleaned with special non-acid based wheel spray cleaners.

#### *Leather, Vinyl, and Rubber*

If your motorcycle has leather accessories, special care must be taken. Use a leather cleaner/treatment to clean and care for leather accessories. Washing leather parts with detergent and water will damage them, shortening their life.

Vinyl parts should be washed with the rest of the motorcycle, then treated with a vinyl treatment.

The sidewalls of tires and other rubber components should be treated with a rubber protectant to help prolong their useful life.

### **WARNING**

**Rubber protectants can be slippery and, if used on the tread area, cause loss of traction resulting in accident causing injury or death. Do not apply rubber protectant to any tread area.**

---

## STORAGE

---

### Preparation for Storage:

- Clean the entire vehicle thoroughly.
- Run the engine for about five minutes to warm the oil, shut it off and drain the engine oil.

 <b>WARNING</b>
--

<p><b>Motorcycle oil is a toxic substance. Dispose of used oil properly. Contact your local authorities for approved disposal methods or possible recycling.</b></p>
--

- Put in fresh engine oil.
- Empty the fuel from the fuel tank, by the pump or siphon.

 **WARNING**

**Gasoline is extremely flammable and can be explosive under certain conditions, creating the potential for serious burns. Turn the ignition key to “OFF”. Do not smoke. Make sure the area is well-ventilated and free from any source of flame or sparks; this includes any appliance with a pilot light. Gasoline is a toxic substance. Dispose of gasoline properly. Contact your local authorities for approved disposal methods.**

- Remove the spark plugs and spray fogging oil directly into each cylinder. Turn the engine over several times with the starter button to coat the cylinder wall. Install the spark plug.

 **WARNING**

**An air/oil mist may be forcibly ejected from the spark plug holes and could get into your eyes. Do not lean over the engine when performing this procedure. If you do get oil in your eyes, wash them immediately with liberal amounts of clean, fresh water and consult a physician as soon as possible.**

- Reduce tire pressure by about 20%.

## 138 STORAGE

- Set the motorcycle on a box or stand so that both wheels are raised off the ground. (If this cannot be done, put boards under the front and rear wheels to keep dampness away from the tire rubber.)
- Spray oil on all unpainted metal surfaces to prevent rusting. Avoid getting oil on rubber parts or in the brakes.
- Lubricate the drive chain and all the cables.
- Remove the battery, and store it where it will not be exposed to direct sunlight, moisture, or freezing temperatures. During storage it should be given a slow charge (one ampere or less) about once a month. Keep the battery well charged especially during cold weather.
- Tie plastic bag over the exhaust pipe to prevent moisture from entering.
- Put a cover over the motorcycle to keep dust and dirt from collecting on it.

### **Preparation after Storage:**

- Remove the plastic bag from the exhaust pipe.
- Install the battery in the motorcycle and charge the battery if necessary.
- Make sure the spark plugs are tight.
- Fill the fuel tank with fuel.
- Check all the points listed in the Daily Safety Checks section.
- Lubricate the pivots, bolts, and nuts.

---

## ENVIRONMENTAL PROTECTION

---

Off-road motorcycling is a wonderful sport, and we hope you will enjoy it to the fullest. However, if improperly conducted, this sport has the potential to cause environmental problems as well as conflicts with other people. Responsible use of your vehicle will ensure that these problems and conflicts do not occur. **TO PROTECT THE FUTURE OF YOUR SPORT, MAKE SURE YOU USE YOUR VEHICLE LEGALLY, SHOW CONCERN FOR THE ENVIRONMENT, AND RESPECT THE RIGHTS OF OTHER PEOPLE.**

To help preserve the environment, properly discard used batteries, tires, oils and fluids, or other vehicle components that you might dispose of in the future. Consult your authorized Kawasaki dealer or local environmental waste agency for their proper disposal procedure. This also applies to disposal of the entire vehicle at the end of its life.

Also take special care not to spill fuel, oil or other fluids onto the ground.

## LABEL INFORMATION

(1)/(4)

USE ONLY DOT3 OR 4 BRAKE  
FLUID FROM A SEALED CONTAINER.  
CLEAN FILLER CAP  
BEFORE REMOVING.  
**WARNING**  
UTILISER DU LIQUIDE  
DE FREIN DOT3 OU 4.

TE03792BN9 C

(2)

**IMPORTANT DRIVE CHAIN INFORMATION**

To prevent an accident and/or damage to the motorcycle, the drive chain must be properly maintained. It should be lubricated every 300km(200mi) and adjusted as often as necessary to keep chain slack at about 35~45mm(1.4~1.8in) measured midway between sprockets on the lower chain run with the motorcycle on the side stand. The standard chain is an ENUMA EK520LV0 with estimated service life of 15000~45000km(9400~28000mi), depending on the severity of use and the frequency of lubrication and adjustment. For safety, replace the chain with only the standard chain any time it wears to over 323mm(12.7in), measured over a 20-link portion pulled straight with 98N(10kgf, 20lbf) of tension. See the Owner's Manual for chain information.

TE03793BN8 C

(3)

### TIRE AND LOAD DATA

The stability and handling characteristics of this motorcycle could become unsafe by the use of improper tire inflation pressures, worn tires, unsuitable replacement tires, or overloading. When tire tread wears down to the limit, replace the tire with only the standard tire. Maintain the inflation pressure specified.

	Air Pressure(Cold)	Size & Maker Type	Minimum Tread Depth
Front	150 kPa (1.50kgf/cm <sup>2</sup> ,22psi)	3.00-21 51P DUNLOP D605FG	2 mm(0.08in)
Rear	Up to 97.5kg Load (215lbs)	4.60-18 63P DUNLOP D605G	2 mm(0.08in)
	97.5~181 kg Load (215~399lbs)		

## 142 LABEL INFORMATION

(5)

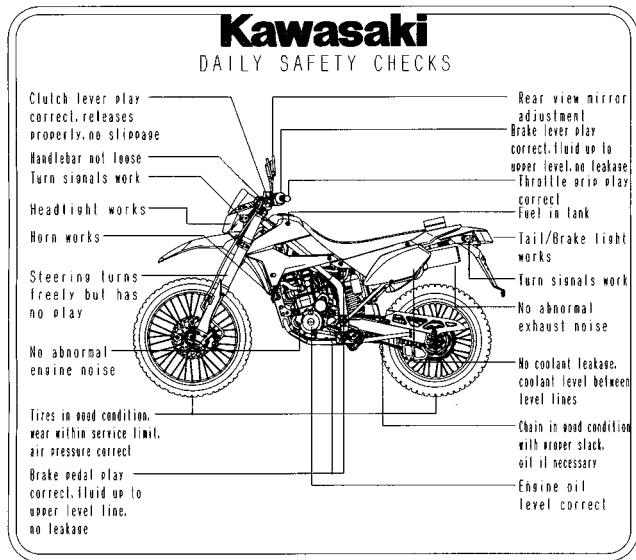





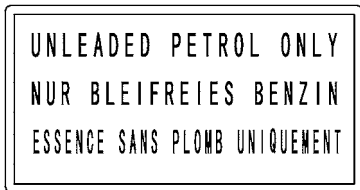





(6)



TE03123BN9 C

(7)

<b>⚠ DANGER/POISON</b>			
 <p><b>SHIELD EYES</b> EXPLOSIVE GASES CAN CAUSE BLINDNESS OR INJURY</p>	 <p><b>NO</b> • SPARKS • FLAMES • SMOKING</p>	 <p><b>SULFURIC ACID</b> CAN CAUSE BLINDNESS OR SEVERE BURNS</p>	<p><b>FLUSH EYES IMMEDIATELY WITH WATER</b></p>  <p><b>GET MEDICAL HELP FAST</b></p>
<b>KEEP OUT OF THE REACH OF CHILDREN.</b>			
     			 <p>LEAD RETURN RECYCLE</p>
<p><b>IN U.S.A., DISTR. BY KAWASAKI MOTORS CORP., USA P.O. BOX 25252 SANTA ANA, CA. 92799-5252</b></p>			

CS9

## ***NOTICE***

**THIS PRODUCT HAS BEEN MANUFACTURED FOR USE IN A REASONABLE AND PRUDENT MANNER BY A QUALIFIED OPERATOR AND AS A VEHICLE ONLY.**

## ***REMARQUE***

**CETTE MOTO EST DESTINÉE À UN CONDUCTEUR QUALIFIÉ ET PRUDENT.**

## ***HINWEIS***

**DIESES PRODUKT IST AUSSCHLIESSLICH ALS FAHRZEUG ZU VERWENDEN UND SETZT DIE ERFORDERLICHE BEFÄHIGUNG DES BENUTZERS SOWIE EINE VERNÜNFTIGE UND VORSICHTIGE HANDHABUNG VORAUS.**

# KLX250SB



\* 9 9 9 7 6 - 1 6 3 3 \*



**KAWASAKI HEAVY INDUSTRIES, LTD.**

Motorcycle & Engine Company

**Part No. 99976-1633**

Printed in Thailand

GB

FR

DE